



SPECIAL ISSUE: THE SEGAL METHOD

THE ARCHITECTS' JOURNAL

The essential method

■ It is an attitude of mind rather than a system of construction.

■ The attitude is one of rigorous simplification of the whole building process from design to completion.

■ The process is rethought from first principles to derive simple yet effective ways of dealing with the fundamental issues of building construction, such as tolerances and thermal and moisture movement.

■ Elements are reduced to their essentials to obtain maximum economy of material and effort.

■ Practical emphasis is given to the processes of planning and construction.

■ The method is very open because it uses materials and techniques that are readily available, rather than specially manufactured for a particular system.

■ This allows maximum benefit to be gained from competition in the market with regard to price and availability of materials.

■ The method can absorb any improvements in techniques and materials' performance.

■ Using standard readily available building materials, assembled on site as far as possible in their market sizes, reduces the processes of production carried out on site.

■ The building materials produced by the supply industry to a consistent quality are considered as finished elements as far as possible.

■ Waste is kept to a minimum.

■ Building board materials such as plasterboard and woodwool slabs are combined to form the enclosure of the building within a framework of standard sections of timber.

■ Much of the approach could, however, be applied to other materials such as steel for both frame and infill.

■ Materials are chosen with regard to their performance and cost. They are easy to work, using simple hand power tools and are of an easily handled size and weight.

■ The building is organised on a

modular grid determined by the sizes of standard materials.

■ Components are assembled using simple dry joints formed with bolts and screws and therefore wet trades such as bricklaying and plastering are eliminated.

■ Foundations and groundworks are reduced to a minimum.

■ The whole building process is simplified so that it can be carried out by one person with basic carpentry skills with the possible exception of services and roofing.

■ The construction is quick and economical.

■ The documentation is simple and consists of small free-hand diagrams of the layout and structure with standard details of junctions, a schedule of materials and a set of instructions.

■ The schedule of materials combines the functions of bills of quantities, specification and order list and provides a basis for accurate ordering and cost control from the outset.

■ The role of the architect includes those of the quantity surveyor and, ideally, the engineer.

■ The simplicity of the construction and documentation makes the whole process 'transparent' and easily understood by someone without experience who can thus become involved in controlling the process.

■ It is possible for someone with no previous building experience to plan the layout and carry out the work if they want.

■ The whole process produces buildings that are not monumental or heavy, or which 'encircle' the personality, but rather that encourage a feeling of lightness and optimism, buildings of their time to be used and enjoyed.

■ They are very adaptable and easy to extend.

■ The method can produce many types of one- and two-storey buildings, incorporating, for example, flat or pitched roofs, courtyards, split levels and double height spaces, 14-17.

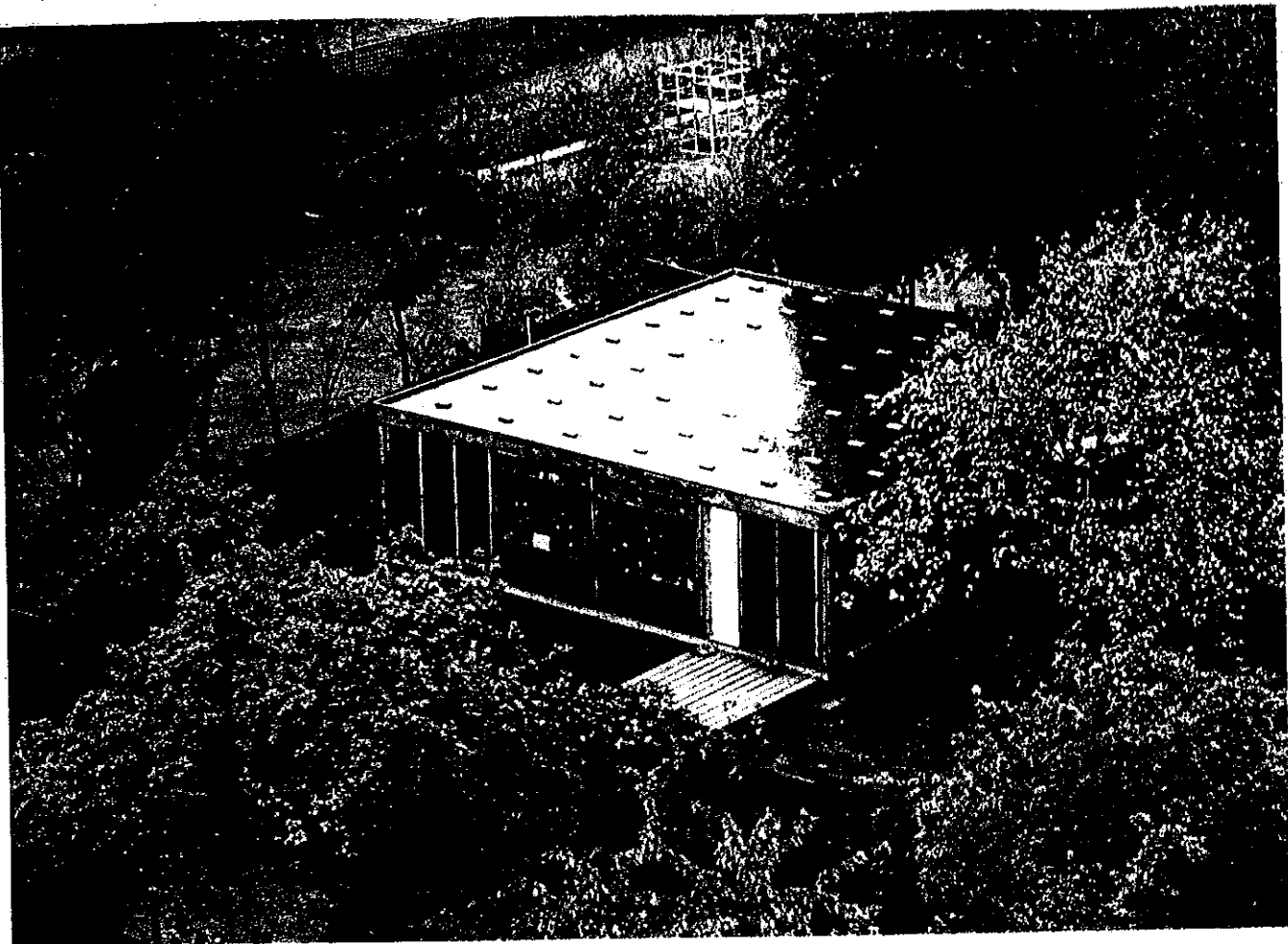

1

- 1 Segal's house at Highgate, London; built in 1962 (AJ 20.6.84 p35).
- 2 Holiday house at Ballygarrett, Ireland, 1968 (AJ 30.9.70 p769).
- 3 House at North Chailey, Sussex, 1969 (AJ 30.9.70 p773).
- 4 Children's home at Singleton, Sussex, 1972.
- 5 House at Mill Hill, London, 1975 (AJ 20.4.77 p716).
- 6 Student's self-build, Stuttgart, 1983 (AJ 27.7.83 p32).

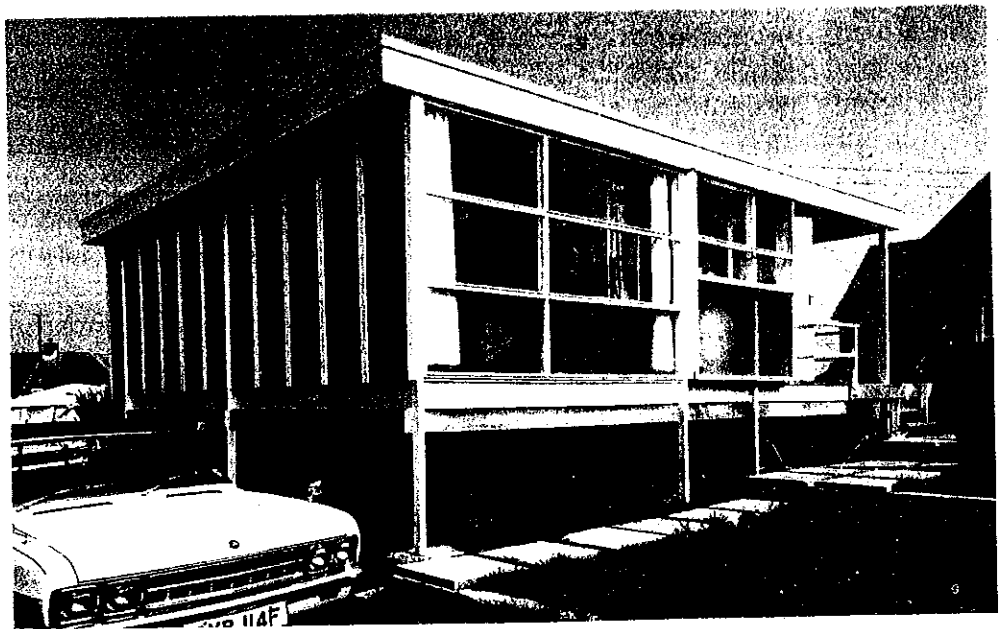

2



3

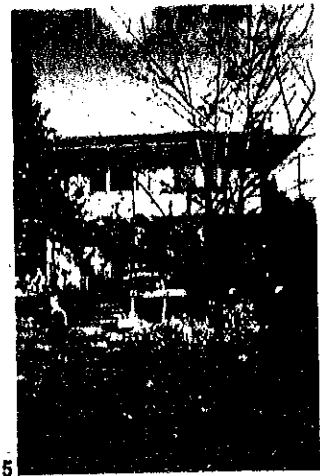
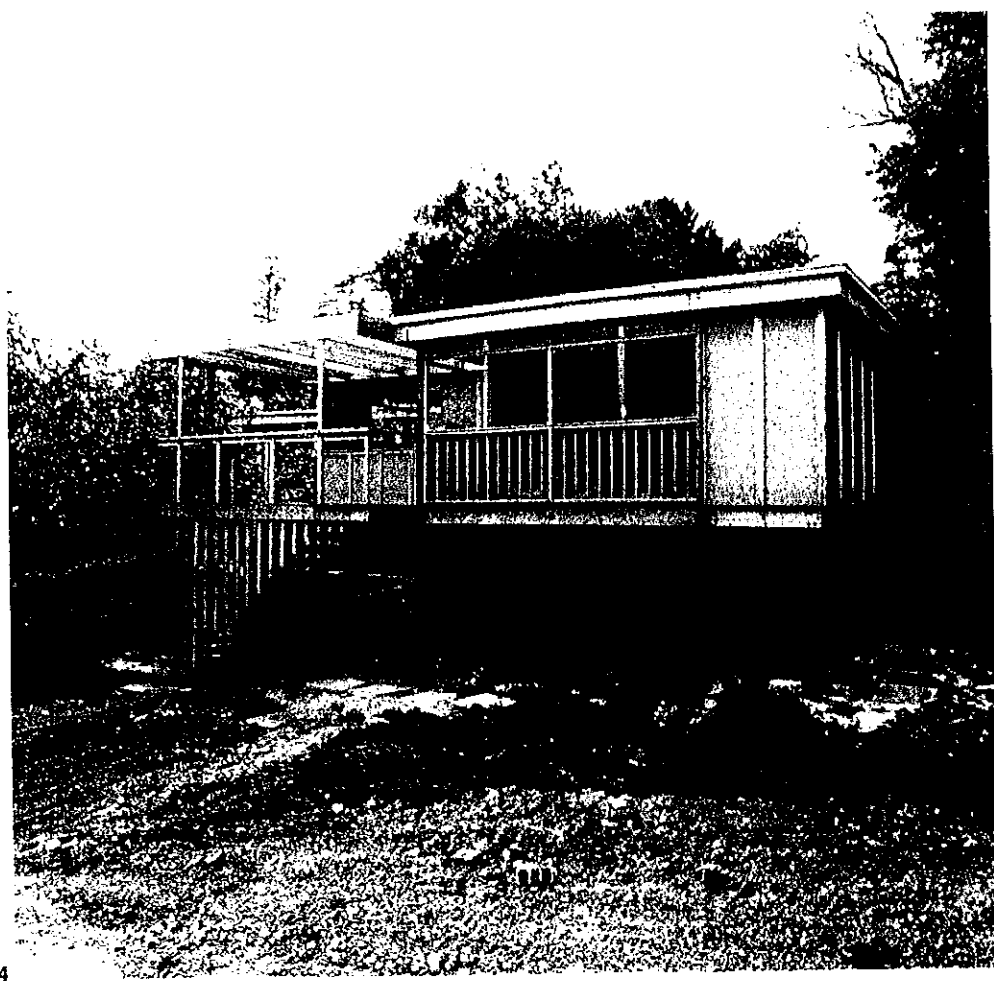

Walter Segal's approach

In 1962 Walter Segal turned his inventive mind to the problem of providing temporary accommodation for his second wife and their combined total of six children while their house in Highgate was being rebuilt. His great experience and knowledge of building enabled him to simplify the whole process of building from start to finish with a rigour that is startling. The house was completed in just two weeks for a materials cost of £800—about £6500 today. It still stands in the garden of the rebuilt house, 1.

A succession of private clients, impressed by the economy and practicality of the method of construction commissioned Segal to build two dozen or so private houses in England and Ireland over the next 15 years, 2-5. And much interest has been aroused abroad. A students' residence based on Segal's ideas was designed and built by students in Stuttgart in 1983, 6. A Segal house was even designed and built using this method after two long telephone calls to Australia in 1980, 9. Other architects have also applied Segal's ideas to their work, 7.

All these houses demonstrate a deep rooted interest in the building process. By using widely available building materials put together in an open ended way, the Segal method reaps the benefits of speed and economy

promised by open system building, while avoiding the monotony and inflexibility that can result from a closed system. Segal also rethought common technical problems such as flat roof failures and condensation from first principles, so avoiding the causes of the billion pound defects that now afflict much system-built housing.

A humane architecture

The Segal houses demonstrate a particular way of thinking about architecture, not just building. Their quality is not monumental or massive, they show a concern for comfort and utility, they respond to the people who live in them and they can be easily altered. It is an architecture of liberation. Their special quality is not to be confused with the lack of substance associated with the idea of 'prefab'. Christopher Alexander defined 'quality' as harmony of form, fitness or purpose together with being ordinary and unremarkable, and I believe that these buildings have that quality.

Segal's houses demonstrate an appropriate vernacular for our time. It is not imposed for stylistic reasons, but uses the basic products of industry and skills that are commonly known and understood. It is essentially an updated version of medieval timber-framing. But just as these

houses contain echoes of a pre-industrial age, they could also be a demonstration of a post-industrial one.

A potential for self-build

The simplification of the building process enables people who are not experts to build a house, and those who are not professional architects to have a controlling influence on designing one. This approach shows how people can participate in a significant way in the housing process and enjoy the sense of satisfaction and achievement that can follow. They can have a house to suit their individual needs and wishes at a relatively modest price. Houses built in this way provide a variety and vitality so often missing from our living environments. People's individual skills, energy and creativity are given expression, and other skills are acquired.

It was in 1971 that one of Segal's private clients, a school teacher, demonstrated the potential for self-build. After watching the carpenter recommended by Segal building his new house for him near Woodbridge, Suffolk, 8, he decided that the work looked so straightforward that he could save himself a lot of money by doing it himself. He telephoned Segal that evening and said he had asked the carpenter to leave the job.

THE SEGAL METHOD

- 7 Vicarage at Melling, near Liverpool by David Lea (AJ 26.11.75 p1121). The article also describes housing at Churt, Surrey by Lea which embodies several of Segal's ideas.
- 8 House at Woodbridge, Suffolk, 1971. First self-build (AJ 3.9.75 p458).
- 9 House in Western Australia, 1980 (AJ 19.8.81 p338).
- 10 House at Lewisham, London, 1980 (AJ 17.12.80 p1185).
- 11 House in second Lewisham scheme, 1986 (AJ 25.1.84 p37).
- 12 Family building.
- 13 Extension under construction.



9



7

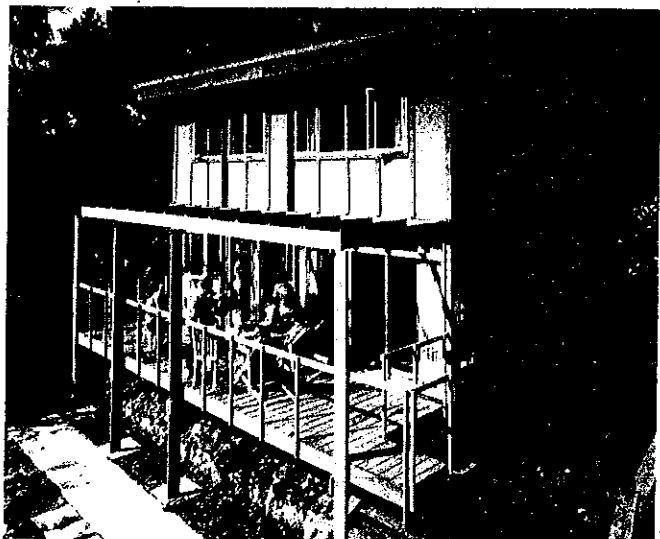

10



8



11



12

Once it had been shown that the method could be mastered by someone without building experience, Segal was keen for a group of people to build houses for themselves. He had to wait until 1978, when 14 families from the council's housing waiting and transfer lists built their own houses in Lewisham, south-east London, 10. The scheme was a success and a second development is nearing completion in Lewisham, 11. No one was prevented from taking part because of their circumstances, lack of capital, income or building skills and indeed houses have been built by people in their 60s and by a single mother. In order that anyone could build, it was necessary to organise land, a suitable financial system and an appropriate way of building. The Segal method proved an essential ingredient in the success of these projects.

The method has several advantages. Each family is able to build its own house individually from start to finish. The families are able to set their own programme of work and fit the building process around other commitments. Parents and children take part, so that it is a truly family enterprise, 12. This alleviates the pressures and conflicts that often occur in self-build schemes which are conventionally organised in a way that discourages family involvement and which requires each member to work a set number of hours per week on each house in turn.

Self-builders do not have to rely on subcontractors because they are able to carry out nearly all the building

operations themselves. This saves money and avoids problems of co-ordination.

Because each family builds its own house, it is not constrained by the usual requirement to build identical houses for reasons of fairness. In fact quite the opposite occurs. Not only have people been able to use the considerable flexibility that this method of building offers in design and construction, but the method also allows people to amend the design as they learn—to move a window to take advantage of a view for example. And a number of houses have been extended. One family built another bedroom for a new child over three weekends for £1200, 13.

The ability to extend, change and improve these houses enables them to be developed progressively in accordance with the occupants' circumstances. This can cut the initial cost and extend the building's useful life beyond the 60 year design life.

Housing standards

The essential simplicity does not necessarily lead to the highest performance, for example when conventional measures of sound insulation are applied. In this case houses are detached, as people want, free of noise nuisance from neighbours. This instance of lateral thinking is typical of Segal's approach. While the method has been developed in many ways since the first house in Highgate, to improve standards of thermal insulation for example, Segal understood very well that there comes



13

a point beyond which further elaboration negates the real advantages of simplicity.

Segal loved to experiment with new materials and techniques, but only when based on knowledge or experience. He would not use untried materials of unproven performance. The following description of the Segal method shows that it has developed considerably by changing from temporary to permanent houses, by meeting rising standards and expectations, by changing from one-off contractor-built Segal designs to self-built houses with a high degree of user control. It will, I am sure, develop further in future.

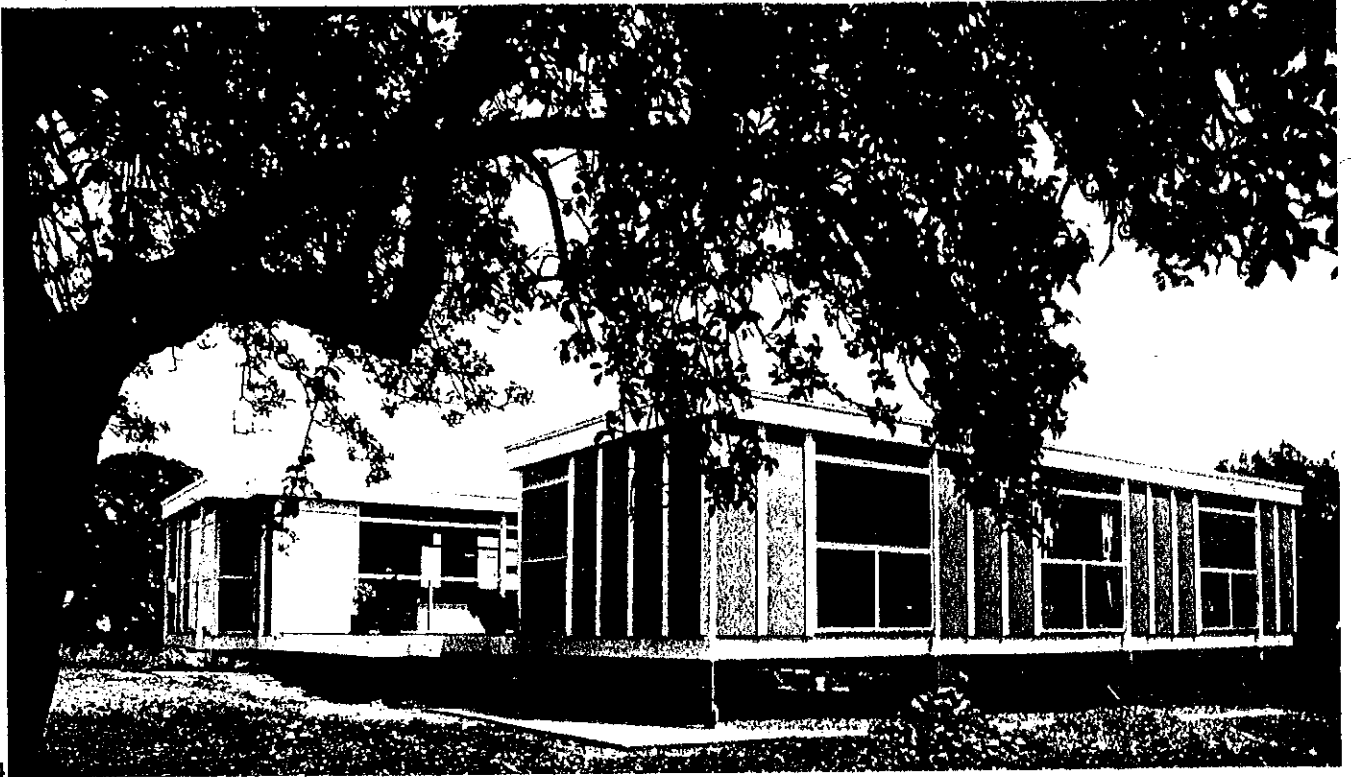

14



15



17



16

14 House at Yelling, Cambridgeshire, 1970.
15 House at Sharnbrook, Bedfordshire, 1980.
16 House at Halstead, Essex, 1969 (AJ 30.9.70 p770).
17 Sheltered housing for old people at Churt, Surrey, 1972. Designed by David Lea.

Typical interior: house at Yelling,
Cambridgeshire, 1970 (AJ 30.9.70 p772).



The type of timber-frame construction known as the 'Segal method', after its inventor who died last year at the age of 78, demonstrates some fundamental attitudes towards building. It questions assumptions about how buildings, not just houses, are designed; how buildings, and not only timber ones, are built; and how buildings, particularly houses, are related to their users. Jon Broome describes the essential features and implications of the Segal method, highlighting the principles behind each element of its design, construction and organisation. This follows the self-build sequence from planning through to finishes.

THE SEGAL METHOD

Walter Segal's approach

The essential method

1 General arrangement

The planning process

2 Modular grid

3 Layout drawings

4 Structural layout

5 Calculations

6 Framing drawings

7 Schedule of materials

8 Catalogue of elements

9 Building instructions

The building process

10 Foundations

11 Structural frame

12 Roof

13 Floors

14 External walls

15 Windows

16 Partitions

17 Ceilings

18 Stairs and other features

19 Services

The future

THE PLANNING PROCESS

1 General arrangement

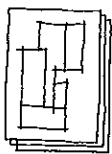
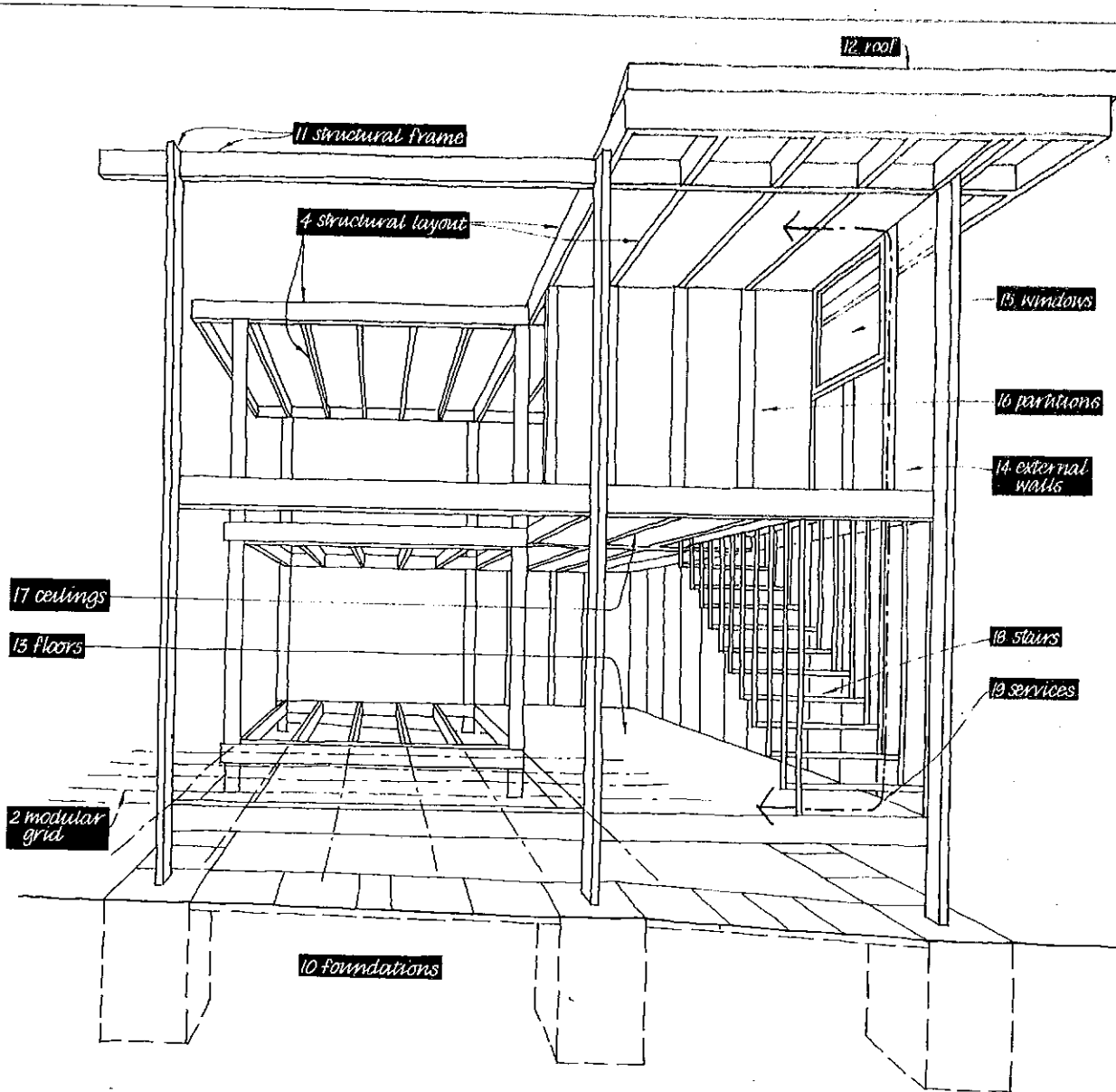

3 layout drawings



5 calculations



6 framing details

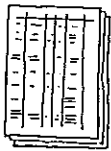

7 schedule of materials

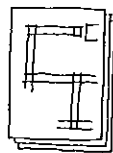

8 catalogue of elements



9 building instructions

Figure 18 shows the general arrangement of the various elements of the method described in the following sections. The order in which they are described here, and on the following pages, is generally the same as the sequence in which they are carried out.

2 Modular grid

Planning commences with the determination of the basic layout. Both the structural frame and the infill walls and partitions are planned on a modular tartan grid. Its dimensions are derived from the width of the building panels, commonly 600 mm or 1200 mm, and from the structural thickness, commonly 50 mm. A tartan grid enables corners to be formed and columns, which are generally 50 mm thick, to be incorporated at any grid position without wasting materials by cutting panels. The disadvantage of this arrangement is that a space is left at every joint position in a straight run of wall which increases the material necessary to form a joint. Nevertheless, the ease with which the infill walls and partitions can be planned on a grid and built using standard panels outweighs this disadvantage.

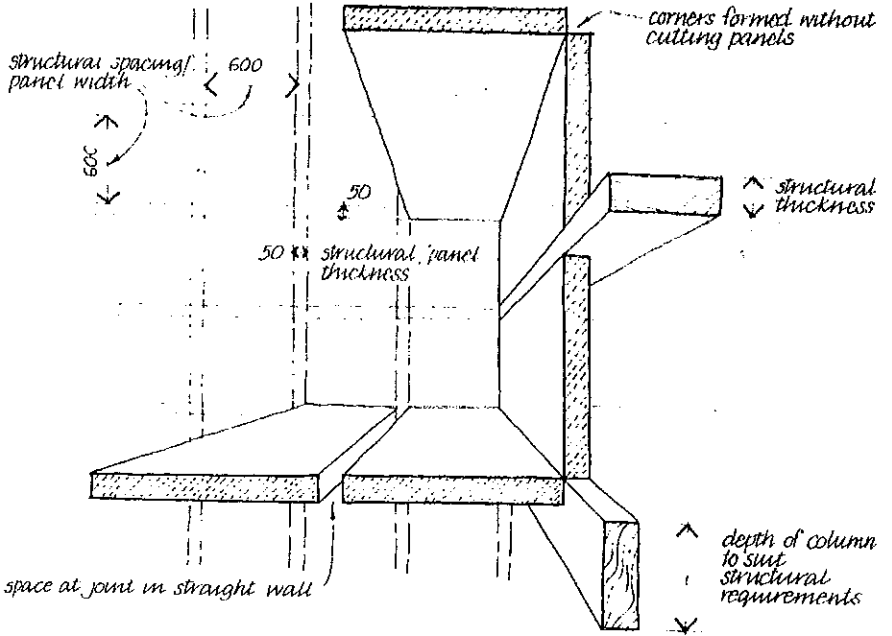

19

Figure 19, a bird's eye view, shows the modular panels and gaps at joints. As columns are deeper than 50 mm, they stand partly outside the grid. These projections are accommodated by locating them outside the building where possible, or projecting from partitions, (see also 26a-c). They are not set longways within the grid, as this would entail cutting the modular panels.

The client can use squared paper and models to develop the layout of the house with the architect and thus exercise a high degree of control over the design process. This self-builder's floor plan, 20, shows that drawings can be simple tools.

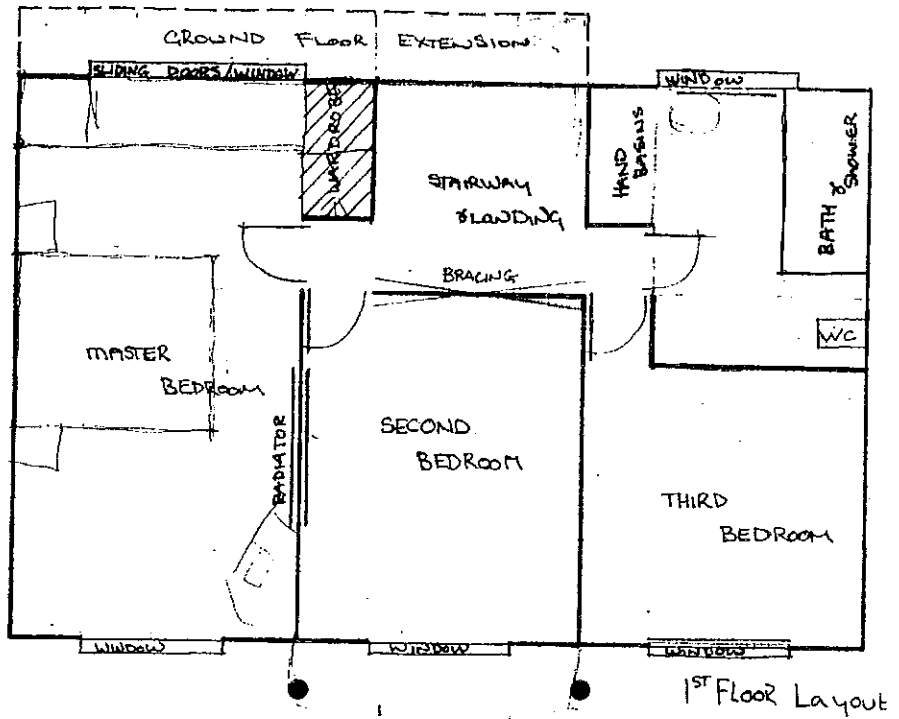

20

Walls do not carry the loads of the building so they can be placed in any position in either floor. Doors and windows can be formed in any position, 21. This has proved a great advantage to people building a house for themselves without experience of visualising spaces from plans. If a wall or a window is not in the right position it can be changed at any stage in the construction process.

The vertical dimensions are controlled by the height of the infill panels and the structural depth of the frame in a similar way to the horizontal dimensions. Ceiling panels can be fixed between the structural frame without cutting, 22, or if cut, then without waste.

21

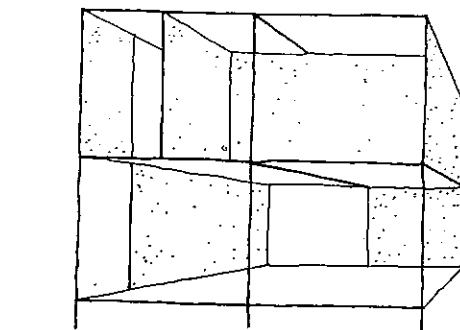

21

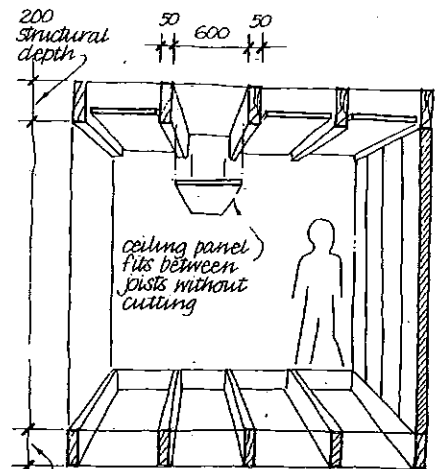

200 structural depth

3 Layout drawings

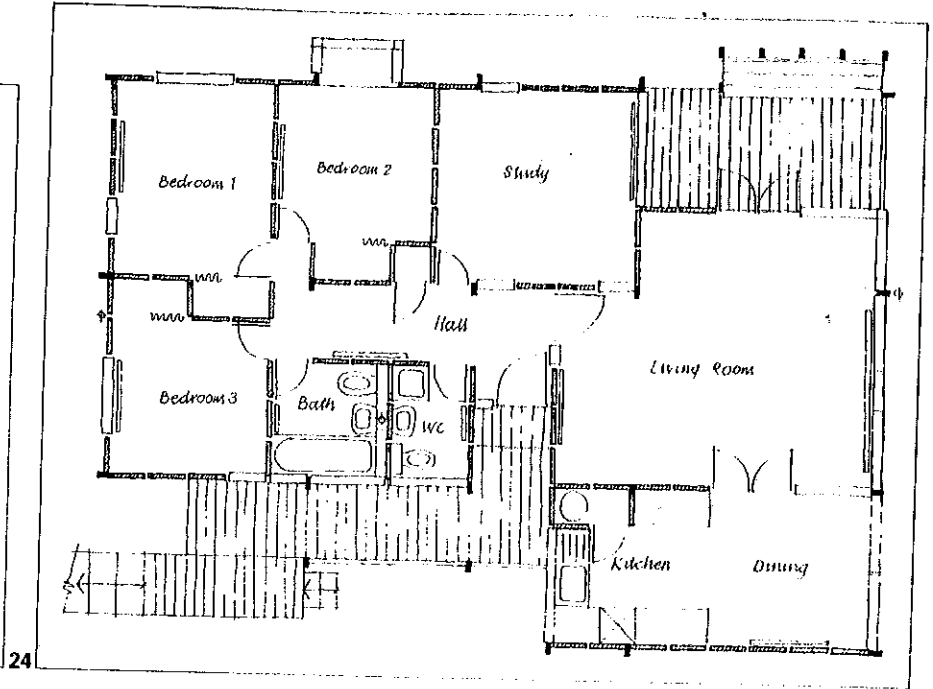
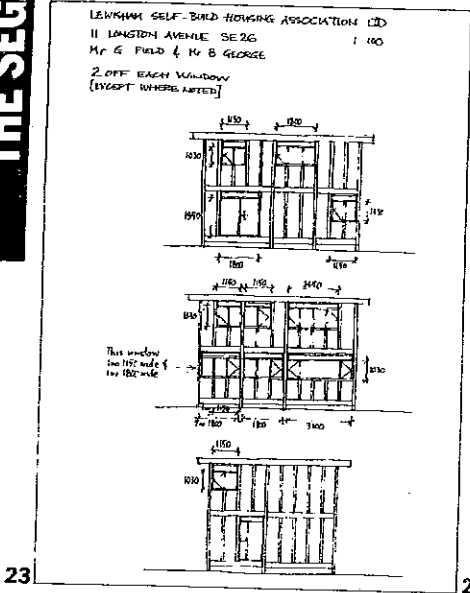

Once the layout has been decided, basic layout drawings can be prepared. These are two or three simple A4 freehand diagrams which show the position of the walls and openings, such as the plan and elevations in

figures 23 and 24. Superfluous information is not shown. The drawings must be used together with the calculations, framing drawings, schedule of materials, catalogue of elements and building instructions

described in sections 5, 6, 7, 8 and 9. Experience shows that layout drawings are referred to only occasionally once the frame is constructed and the modular arrangement of the building is clear.

4 Structural layout

When the basic layout has been determined the structural layout can be worked out. The structure is a post and beam frame, 25a, unlike the stud wall panel construction commonly used in timber houses built today, 25b.

While a frame structure is not usually as efficient a use of timber as a panel structure, it has other advantages. The extent and therefore cost of foundations is considerably less. And a frame offers great planning freedom and adaptability. Indeed, unlike most framed buildings,

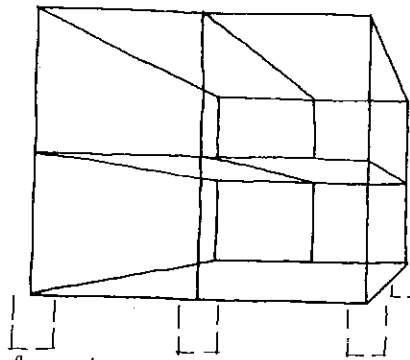

25a frame structure

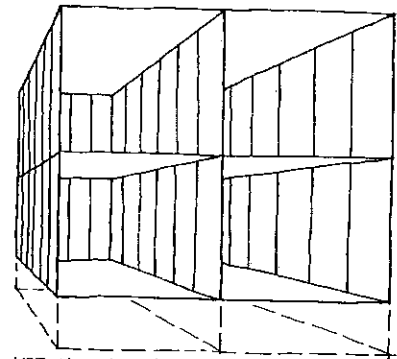

25b NOT structural panels

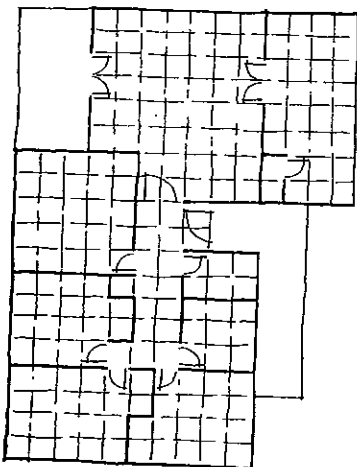

26a partition layout decided first

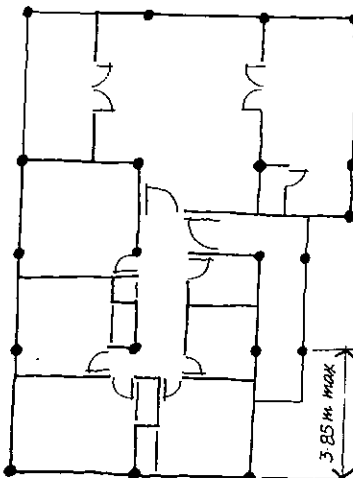

26b column layout follows partition layout

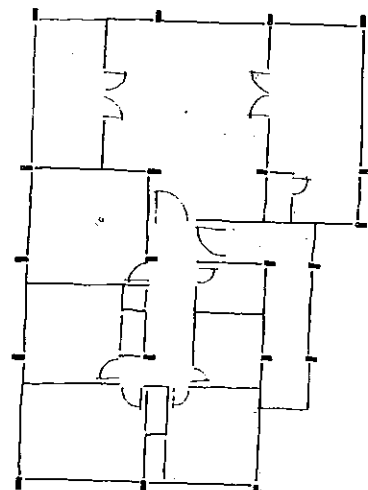

26c columns partially outside partition grid

Frames are stacked in order of erection. The first frame is erected and securely braced in position with struts into the ground, 38. The remaining frames are raised, 39, and temporarily braced to the first with timbers used later on in the construction process, 40, until the permanent bracing is fixed in position. The temporary braces can be removed one at a time to adjust the frames for square and position, 41.

Framing uses slender sections of stress graded, imported softwood, pressure treated against rot. Rigid joints are formed with galvanised steel bolts (in place of the medieval mortice and tenon joints held together with wooden pegs).

The form and proportion of the frame have more in common with steel rather than timber framing. The slender sections allow the frames to be handled without difficulty.

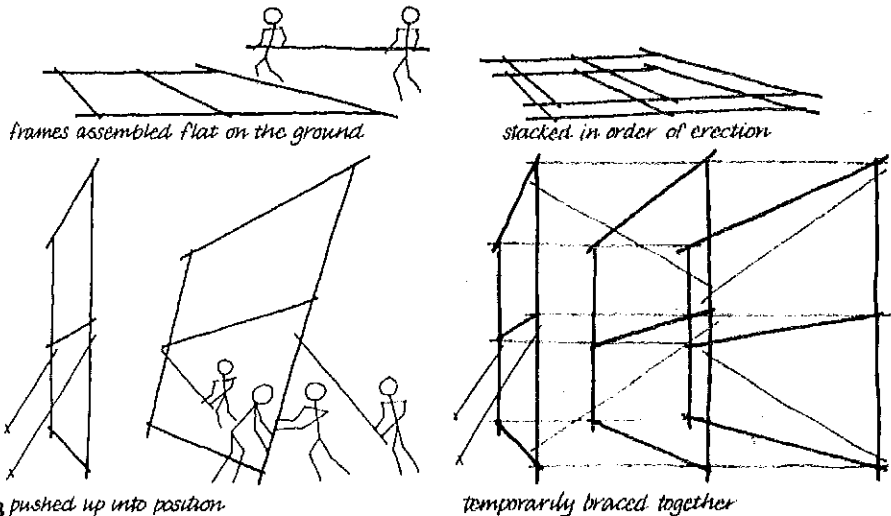

38 pushed up into position

temporarily braced together

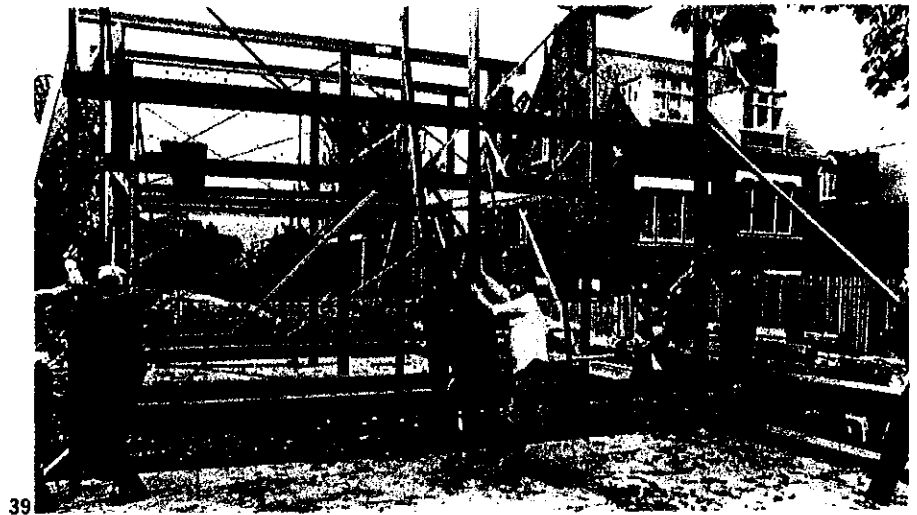

39

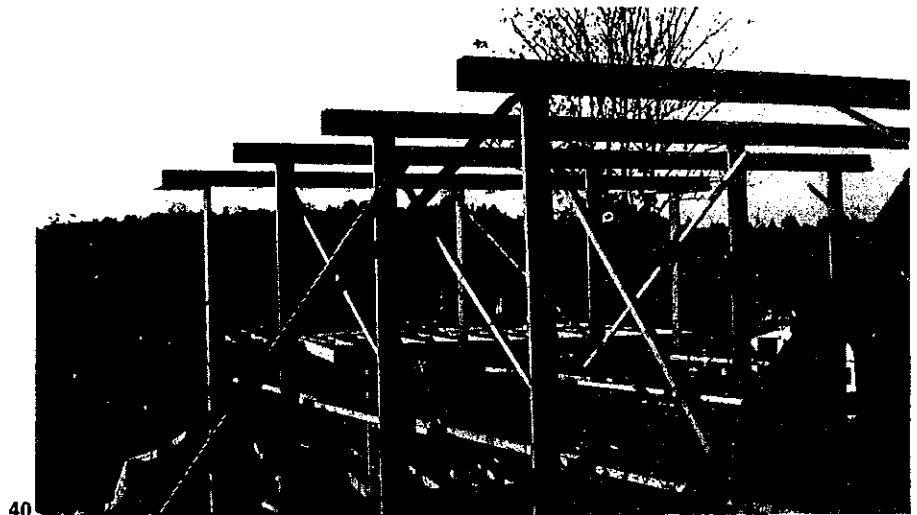

40



41

the Segal frame is sufficiently adaptable to allow the plan of the building to be determined first, 26a, and then the frame to be designed to suit the plan, 26b, and column space

allocated, 26c. Columns can be spaced up to six modules apart in either direction, which gives an optimum span beyond which the deflection of beams becomes critical. This gives a

structural bay of up to 3.85 m in either direction, which will accommodate most domestic size rooms. Composite beams or trusses can be incorporated for larger spans.

5 Calculations

When the structural layout has been fixed, the structure is calculated to ensure that it is adequate and to determine the most economical form consistent with other requirements, for example, the integration of the structure with the plan and the constructional discipline. Particular attention must be given to the design of the joints, which are often the most critical part of a structure of this kind.

A set of calculations has to be presented for Building Regulations approval which typically includes tabulation of dead and imposed loads, calculation of wind loads, bending and deflection calculations of critical beams and joists at floor and roof levels, calculation of critical columns for axial and bending loads, calculation of joints, wind overturning effects and soil bearing pressures. A set of such calculations might be about a dozen pages, such as the example of a floor joist bending calculation, 27.

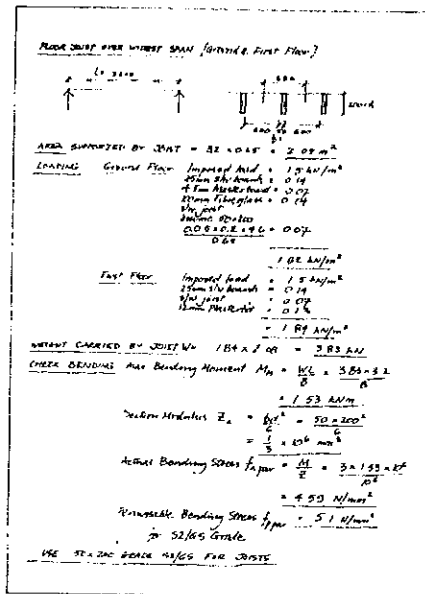

27

6 Framing drawings

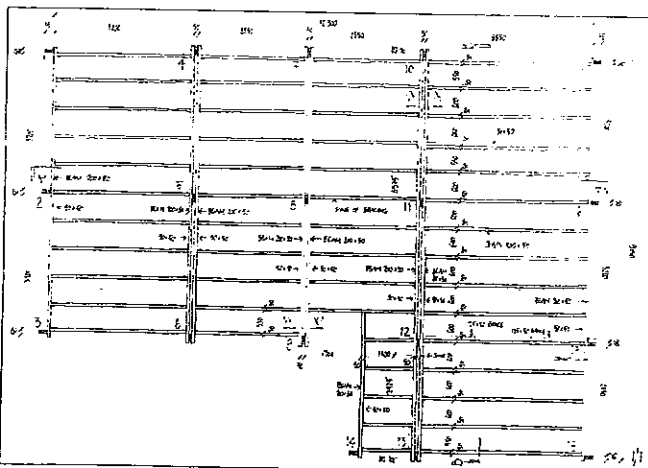

28

Once the structure has been checked by calculation and amended as necessary, the drawings of the frames are prepared. Again they are A4 freehand diagrams, such as these typical ground floor plan and sections, 28, 29. Framing drawings show the dimensional information necessary to construct the frame. A typical set of drawings would include a foundation layout, plans at roof levels, sections and details of joints—about eight sheets altogether.

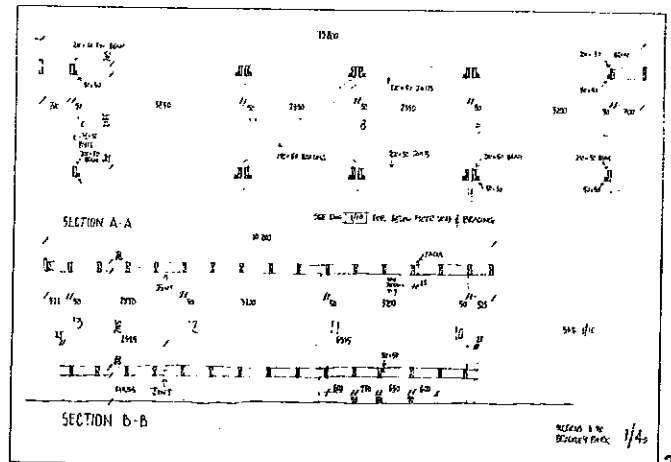

29

9 Building instructions

These are the final elements of the documentation and are a simple step-by-step description of the building process, annotated with diagrams as necessary. The example, 32, describes construction of the main cross-frames.

Self-builders without building experience also attend a short course of evening sessions. Typically a course of 12 evenings would include sessions explaining the method and documentation presented with slides, models and drawings, and sessions in the workshop building up confidence in using both hand and power tools, making typical joints and learning

the basic techniques of plumbing and wiring.

Once self-builders get on site they learn readily by example, devise their own ways of doing things and pass on information to one another. In Lewisham regular meetings are held to monitor progress and pass on information. The architect is available for advice on the telephone in the evening and visits the site regularly at weekends. While training and supervision are important, it is vital that people approach the job in the right frame of mind. They must be careful, methodical, think operations through and plan ahead.

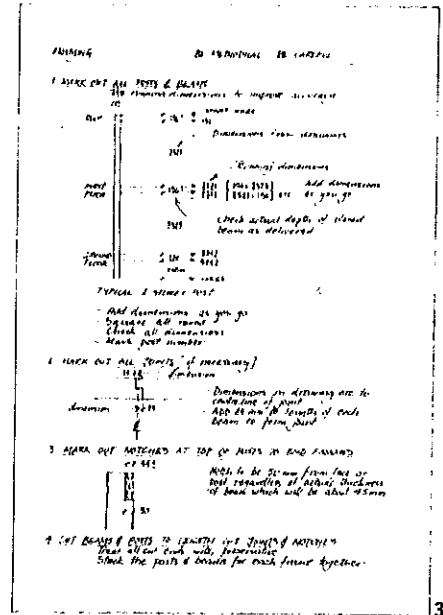

THE BUILDING PROCESS

10 Foundations

At last, after the planning, finding land, obtaining consents, arranging finance, preparing documents and obtaining materials, the moment to break the ground has come. Building can begin. The essential feature of the foundation arrangement is that the building stands above the ground on posts rather than being built in the ground in the conventional way.

Foundations generally consist of separate in-situ concrete bases constructed below each post position. They begin with digging a hole. When the building inspector approves the bottom, the hole is filled with concrete and capped with a concrete paving slab set at a slight fall. The posts (columns) stand on the slabs on a piece of lead which is forced into the end grain of the timber by the weight of the building. This seals it against moisture.

The topsoil is removed below the building and is replaced with gravel contained within a border of paving slabs. A concrete oversite slab is not required, 33. The reduced extent of foundations enables them to be dug by hand and the amount of concrete required can be placed using wheelbarrows, 34. This avoids the costs of both ready-mixed concrete and machine excavation and also makes it easy to operate on restricted sites. It renders the groundworks a manageable self-built operation.

Foundations are constructed at whatever ground level exists without levelling the site. This removes the necessity for them to be constructed at any particular level and thereby cuts out an operation that inexperienced

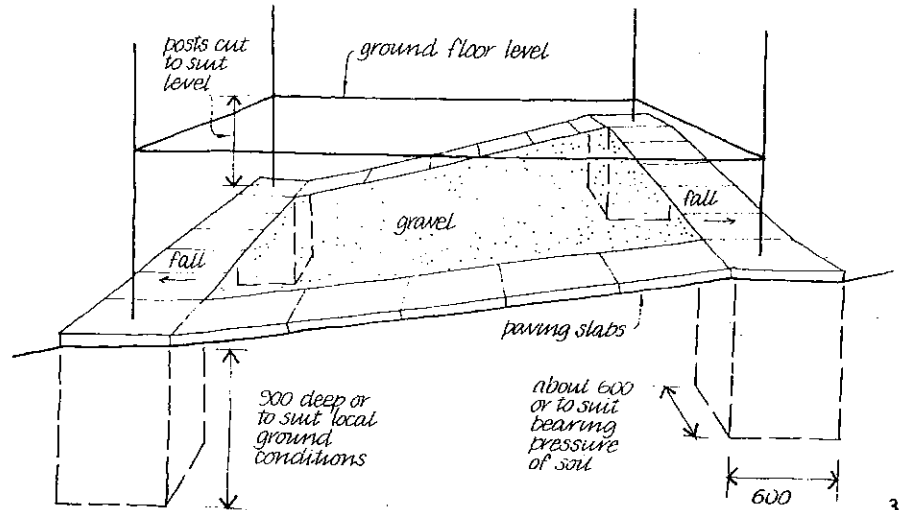

builders have particular difficulty in carrying out accurately. It also means that this type of building can be constructed on a sloping site without incurring any significant increase in costs, and that trees are not damaged if buildings are positioned close to them.

A typical three bedroomed bungalow might have 18 such concrete bases, a two-storey house about 12. Isolated bases of this kind supporting the posts of a frame structure are less extensive and therefore less expensive than the continuous foundation required under a loadbearing wall.

Levels are taken and each post is cut to length to suit so that when the frames are erected the floors come out precisely level. An undercroft is formed below the building which makes a useful storage 'cellar', 35.

The posts stand on the foundations, but are not anchored to them. The weight of the building keeps them in position. This arrangement means that conventional tolerances are not relevant with regard to the positioning of the foundations because once the frames have been erected the position of the posts can be adjusted for distance and square independently of the foundations, 36. The need for the foundations to be set out accurately is also removed. This in turn cuts out an operation that is difficult for inexperienced builders to achieve successfully.

Short bored piles have proved to be an economical tying because ground beams tying the piles together are not necessary. Such a foundation is quick and particularly suitable in areas of poor soil conditions.



35

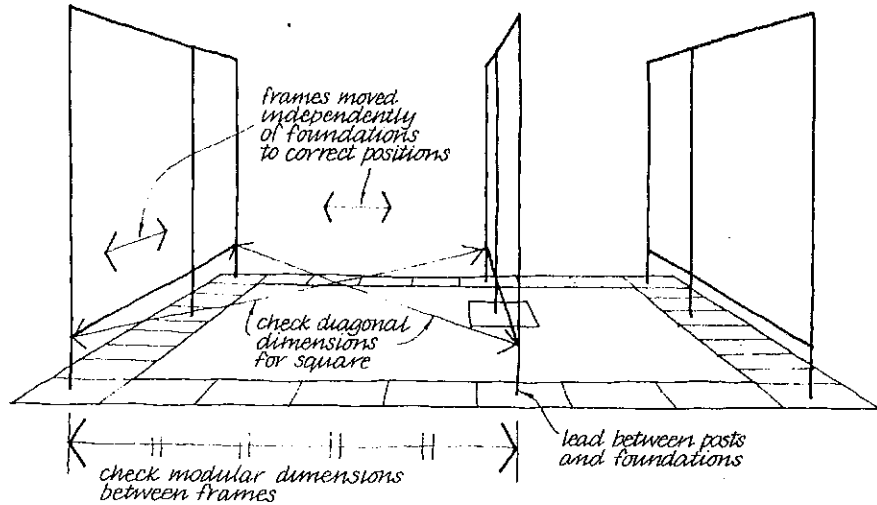

36

11 Structural frame

The completed oversite construction provides a base for construction of the frame. In common with medieval timber framing techniques, the Segal method consists of a number of cross-frames with rigid joints assembled flat on the ground, raised into position and braced together to form the overall structure, 37.

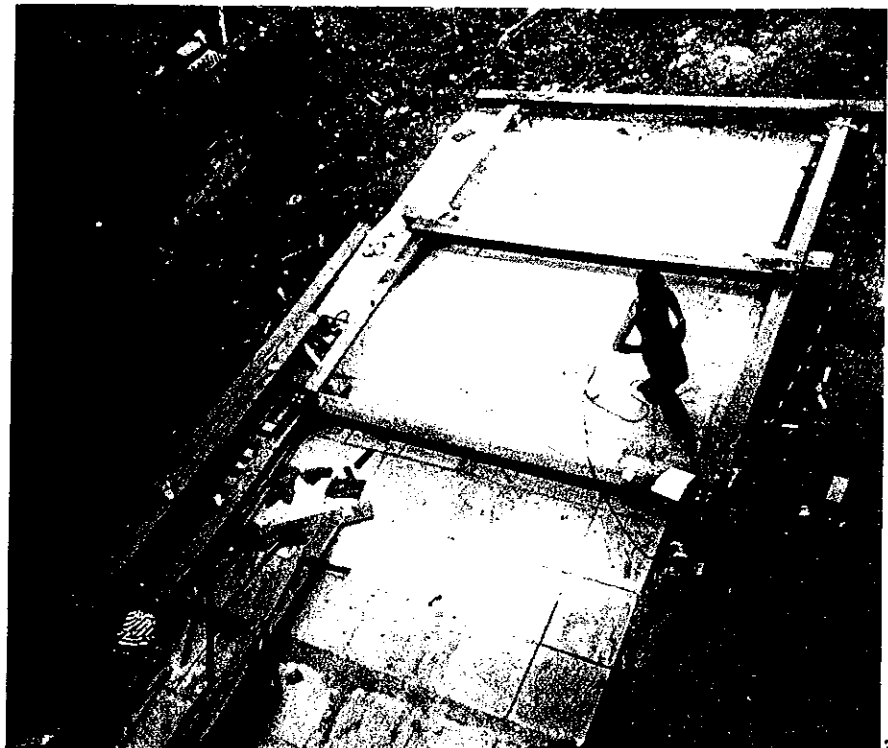

37

Frames are a form of portal frame with rigid joints that resist horizontal wind forces in the plane of the frame. However, unlike a conventional portal arrangement, there is a tie beam at floor level which eliminates the horizontal reactions at the base of the column, 44. This is what allows the building to stand above the ground without being anchored to it with the attendant advantages of ease of construction and elimination of critical tolerances in the foundations.

Frames are rigid in one direction but have to be braced together in the other to resist wind forces. The floor is fixed so that it forms a rigid horizontal plate that transfers horizontal forces from all parts of the building to the position of the bracing. (The method of construction could provide for the roof to be an effective plate also.)

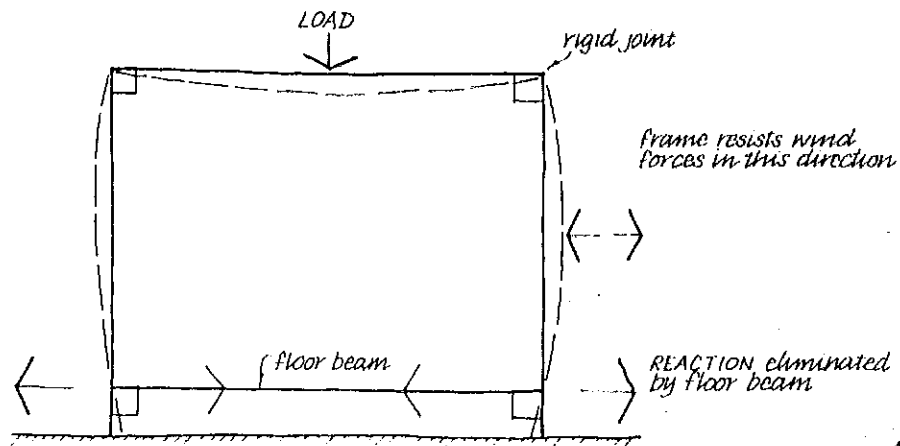

44

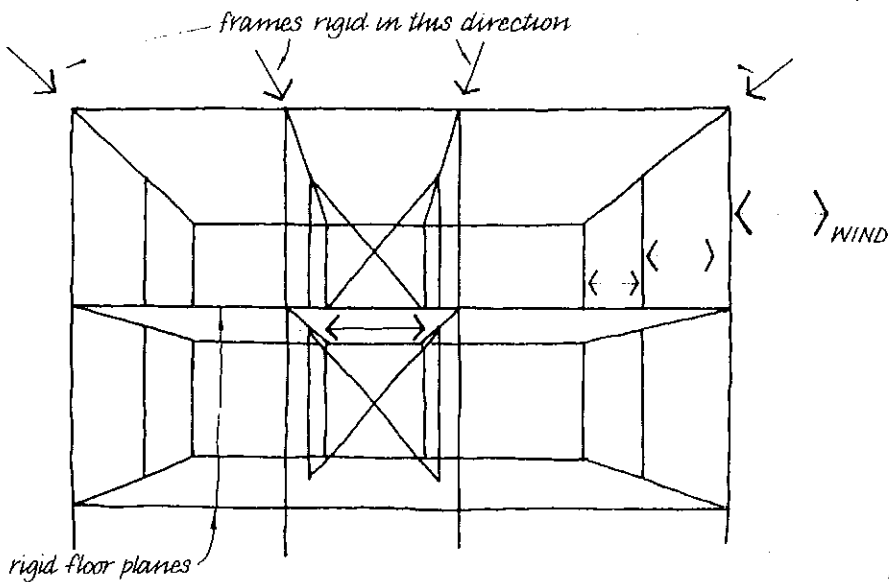

45



42

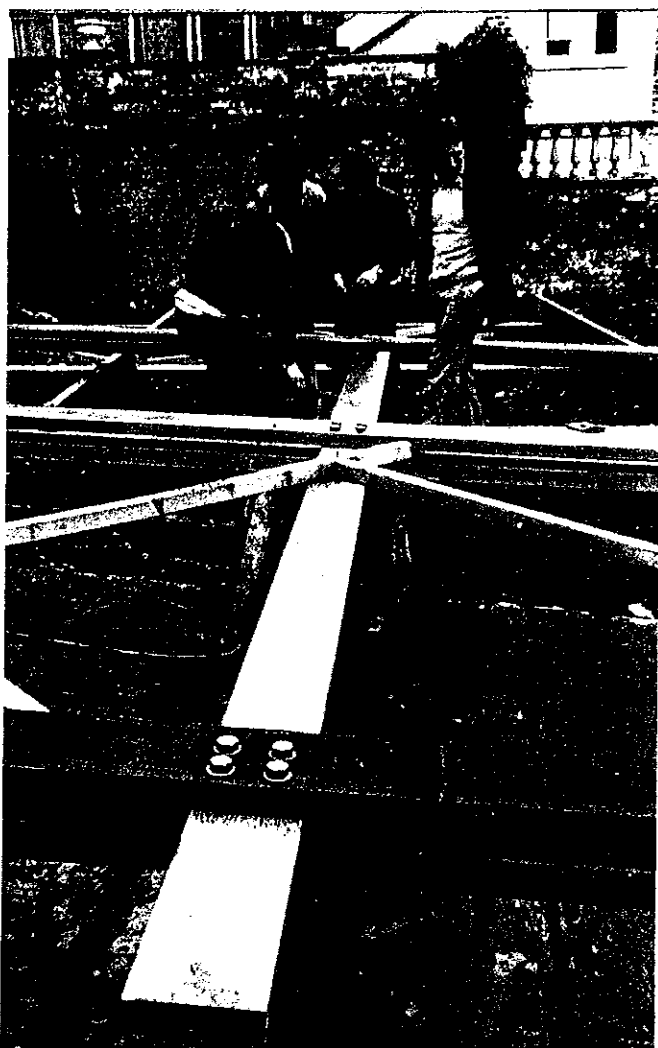

46



43

Bracing is generally in the form of a cross-brace at each floor level extending for one bay at a convenient position near the centre of the building, 41, 42, 45. The lower wind forces generated in the frame of single-storey houses allows the use of knee braces below the floor level, 43. This avoids the planning limitation that a bay of fixed bracing above floor level imposes.

The size of the bolts at the joints is given by the load on the joint and the type of timber. Bolt sizes in turn dictate the minimum spacing between the bolts and between the bolts and the edge of the timber, 46.

Frames in the centre of the building are constructed with double beams, whereas single beams are used for these at the edge of the building. This means that all the beams carry a similar load, 49.

Once the frames have been erected and braced, the joists are fixed between them at roof and floor levels. Their spacing and thickness conforms to the modular grid, 47. Equally important, the beams and joists have the same depth so that when fixed using a bearer on the side of the beams the undersides of both beams and joists are at the same level, 50, 51. As there are no beams projecting below the ceiling level, all the wall panels are the same height.

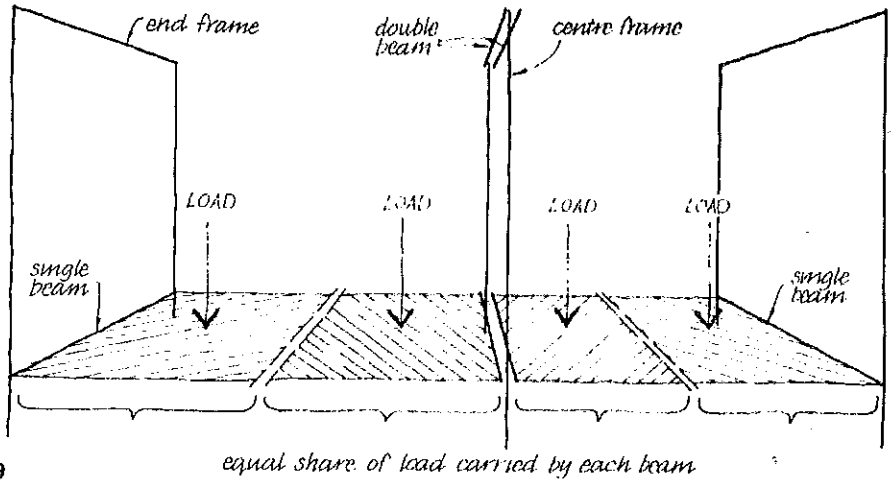

49

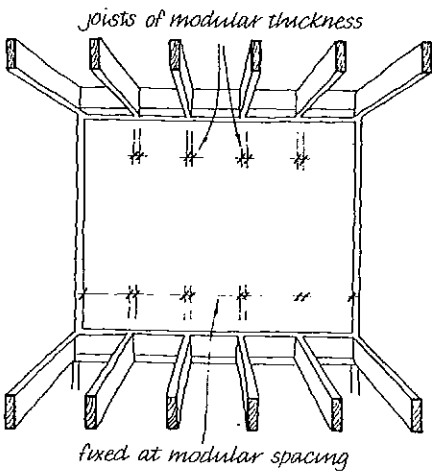

47

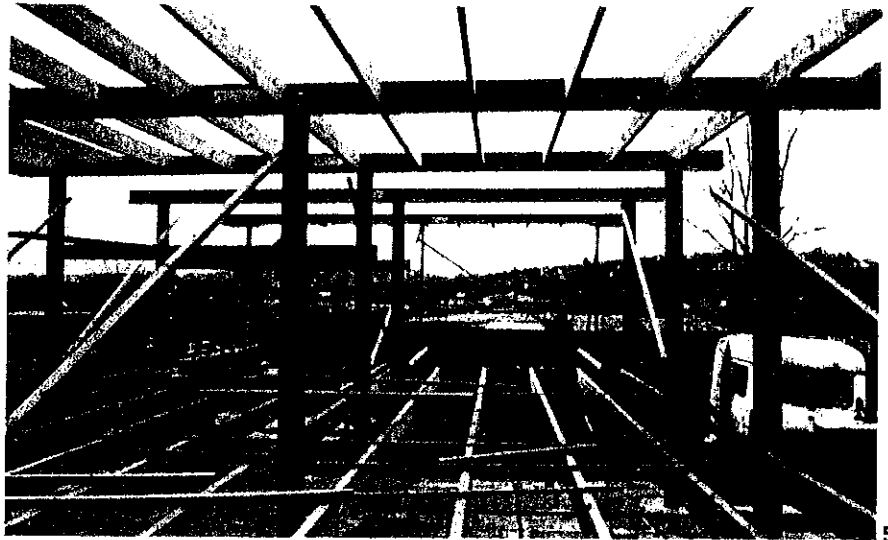

50

Having beams and joists of the same depth is possible because the timber used for the heavily loaded beams is much stronger than that used for the joists.

Timbers used later in the construction are fixed temporarily to the posts to provide a safe working platform at a convenient height for fixing the joists at the upper levels. Scaffolding is not necessary, 48.

The frame can be designed with projecting cantilevers, 52, in which case deflection becomes the critical factor.

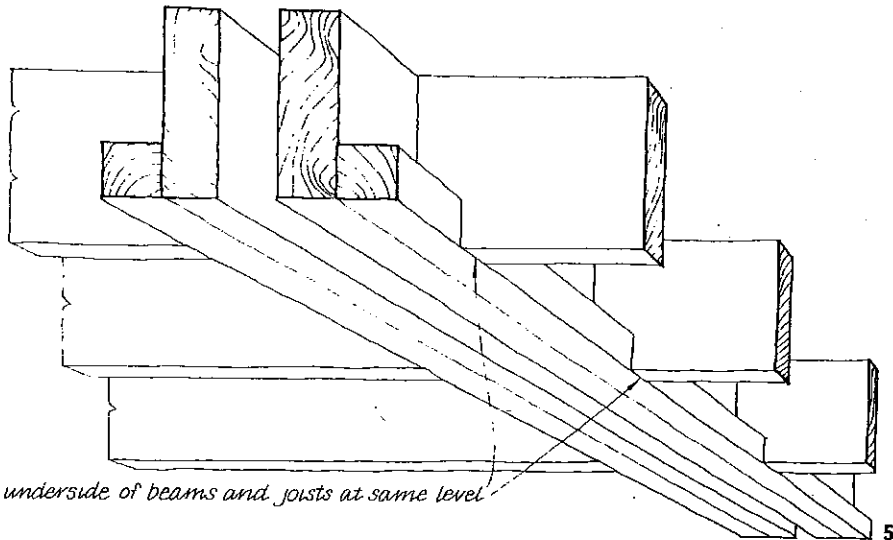

51



48



52

12 Roof

Once the frame is completed constructing the roof is the next operation. This allows all subsequent operations to be carried out under cover, 54.

Many forms of roof are possible, but a flat roof has particular advantages. It is quick and easy to construct, economical and can fit over any plan shape without difficulty. A flat roofed building can be extended in any direction without problems.

Many people have a visual prejudice against flat roofs and there are well founded reservations about their performance. However, Segal rethought flat roof construction from first principles to avoid the problems that commonly lead to their failure. The waterproof membrane is not fixed down, but is laid loose on top of the roof deck. The membrane is also not fixed at the edges. In other words, the waterproof layer on the building is draped over the roof rather in the manner of a tablecloth, 55. This means that any structural movement in the deck or timber frame of the building is not transferred to the membrane causing a crack and a leak. Furthermore, the membrane is free to expand and contract without restraint, avoiding wrinkles and tears at the edges which ultimately would lead to failure of the membrane. (Many large flat roofs are now designed on this 'loose lay' principle.)

The roof has a generous overhang all around which affords a great deal of protection to the building. The effect is to create almost a 'microclimate' of shelter immediately around the building, 53. The roof outlet is the only roof penetration and is positioned in this overhang so that the joint is fail-safe.

The roof deck comprises woodwool slabs laid loose on the joists. It is



54

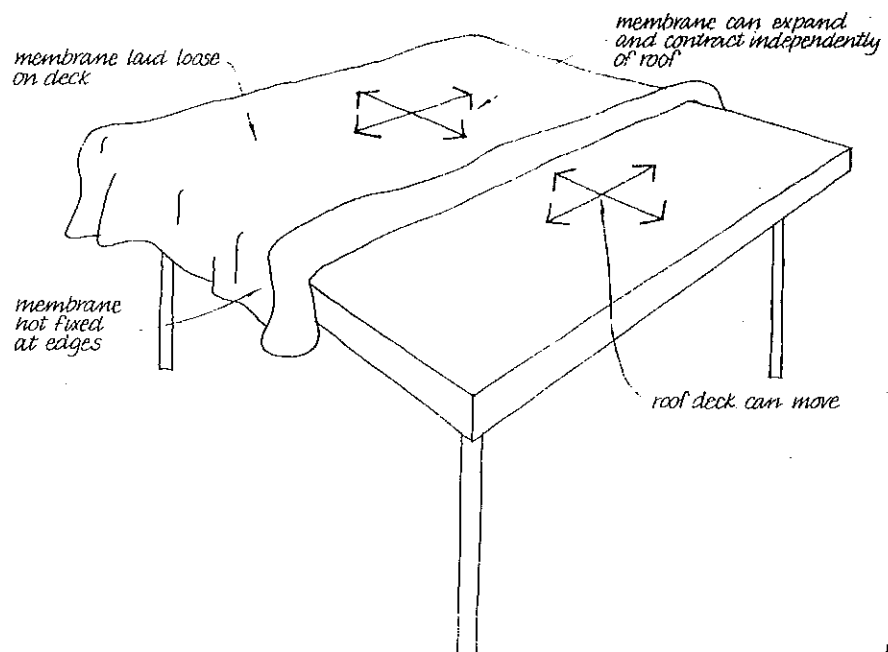

55

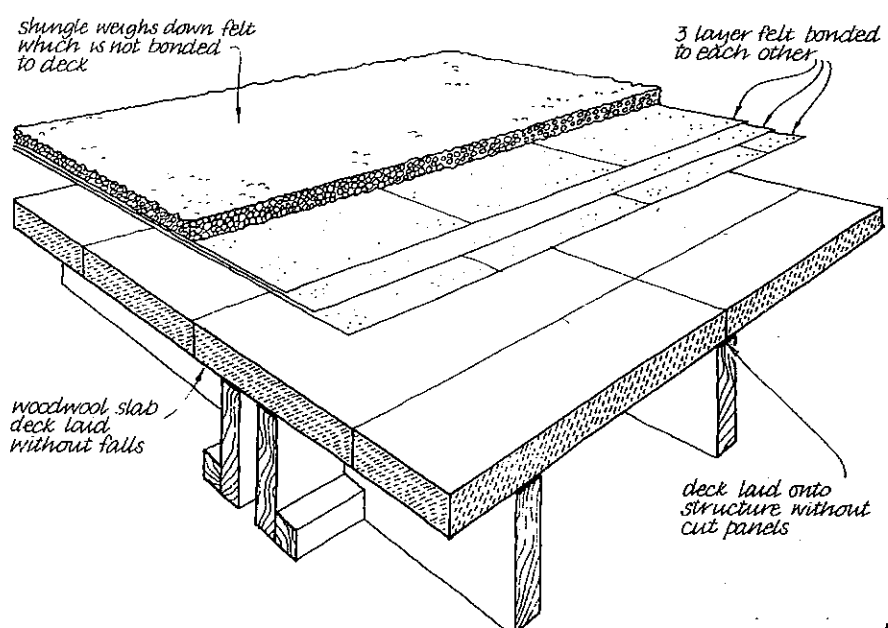

56

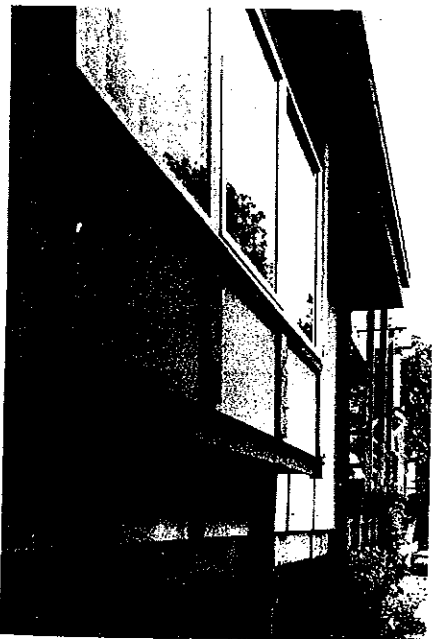

dimensioned to avoid cutting the slabs. The deck is laid level over these slabs without any falls. With a perimeter upstand, the roof is wet at all times which keeps the membrane at a relatively even temperature.

The membrane is commonly a conventional three layer build-up of bituminous felt, for economy. Layers are bonded one to another with hot bitumen but not to the roof deck. This is generally a job for a professional roofer, although cold bitumen or a single layer butyl rubber membrane could make this a self-build operation. This could eliminate all subcontractors.

The membrane is weighted down with a 40 mm layer of 20 mm diameter shingle, which also serves to keep direct sunlight off the felt, 56. The felt is carried up and over an upstand at the edge of the roof and turned down over the top of the fascia. This way, if the roof outlet should get blocked for any reason any build-up of water will simply flow over the upstand without harm and indicate that there is a blockage. The edge of the membrane is

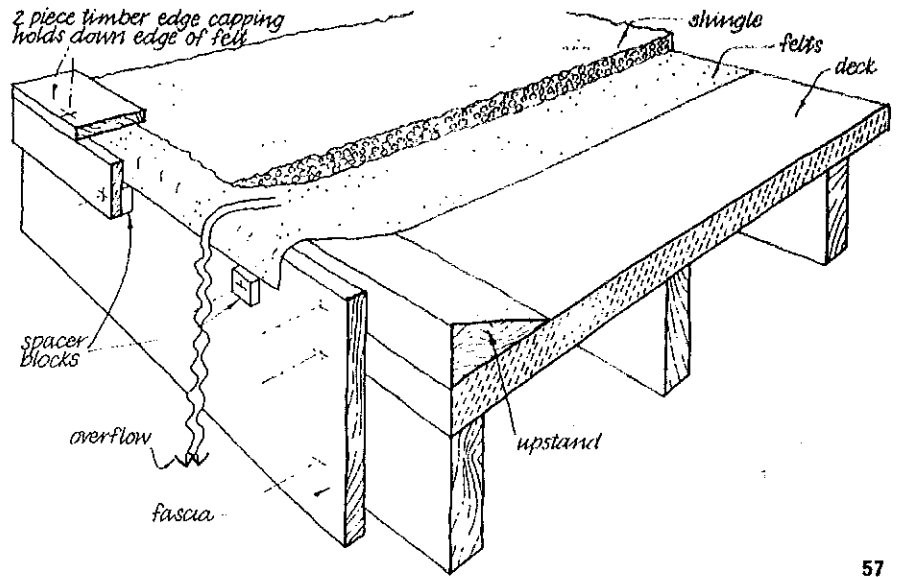

wedged in position with a timber capping section fixed through spacer blocks below the edge of the felt, thus avoiding any fixing to the felt itself, allowing it to expand and contract without problems, 57.

The roof is commonly insulated at

ceiling level and the void above the ceiling is ventilated by virtue of being loosely constructed, so avoiding the build-up of interstitial condensation. A roof of this kind is also very easy to insulate on the outside as an upside-down roof.

57

13 Floors

Once the roof is completed floors are fixed. These are generally conventional tongued and grooved softwood boarding on joists, 58. (Since walls are not in place at this stage, chipboard flooring would be vulnerable to the weather.)

The ground floor is raised above the ground and therefore has to be insulated against extra heat losses. The raised floor gives an undercroft the whole extent of the house for storage.

It is also easy to run services within this space. Insulation is laid between joists on panels which can be removed to gain access to services, 59.



58

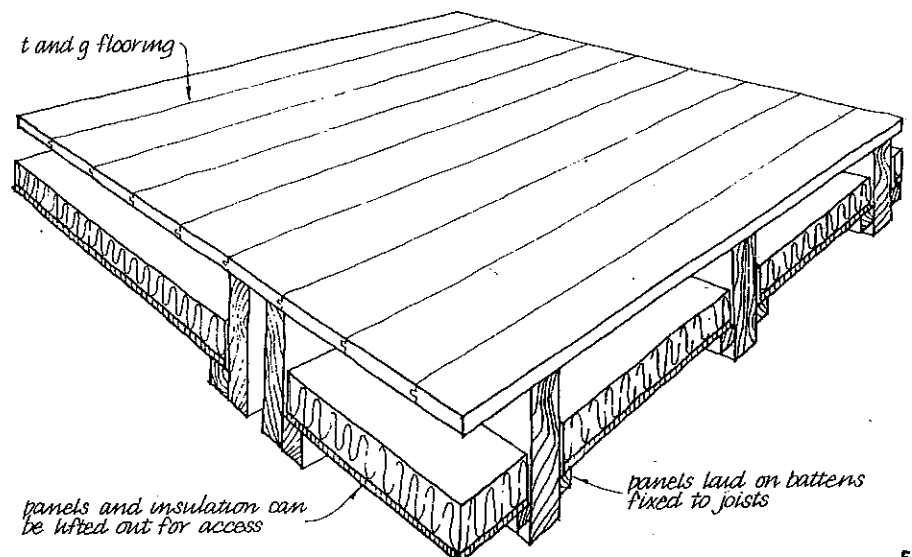

59

14 External walls

Once floors are fixed they provide a working platform from which to construct the walls. External walls are non-structural infill clamped into the structural frame. Clamping is done with bolts; the bolt heads can be seen in figure 60.

Walls are formed by combining layers of readily available building boards to form a sandwich. The filling is an insulating and structural core with a weatherproof external finish and a decorative internal finish.

Segal likened the walls to clothes—comfortable vest on the inside, with a jumper to keep you warm and a raincoat to keep you dry on the outside, 61. Just as clothes fit loosely so that sweat does not build up, so too this wall construction relies on a loose fit between the layers to allow a certain amount of air to circulate in order to prevent the build-up of condensation. This approach is safe, as it does not rely on a vapour barrier, the integrity of which cannot be guaranteed. However, it does lead to higher ventilation heat losses.

The materials that form the sandwich are selected to give the performance required for a particular situation. Products are chosen, say, to give the required degree of thermal insulation and design life. Panel sizes are selected to eliminate cutting panels and waste as far as possible. Commonly the materials are fully compressed fibre cement panels with an enamel finish on the outside, painted plasterboard on the inside, with a core of 50 mm woodwool slabs between.

Extra layers can be incorporated into the construction. A layer of urethane foam will improve the thermal performance, for instance, or a layer of plastic laminate on the inside will provide a washable surface for a splashback around a bath.

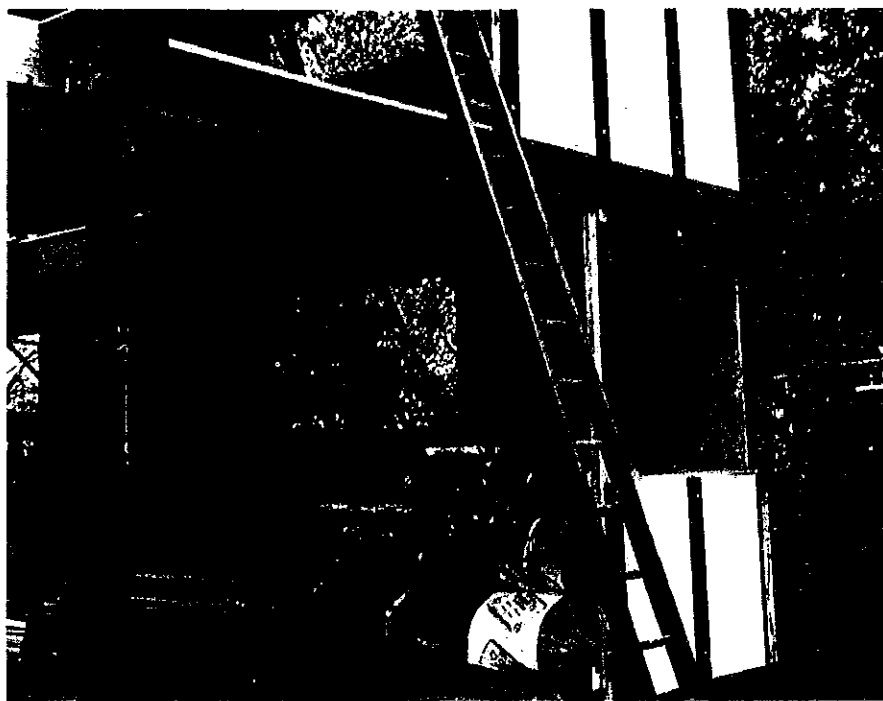

60

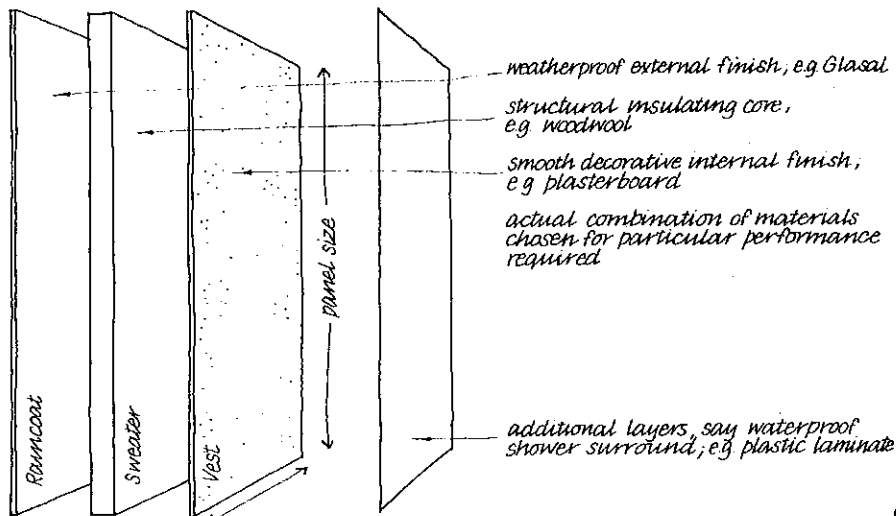

61

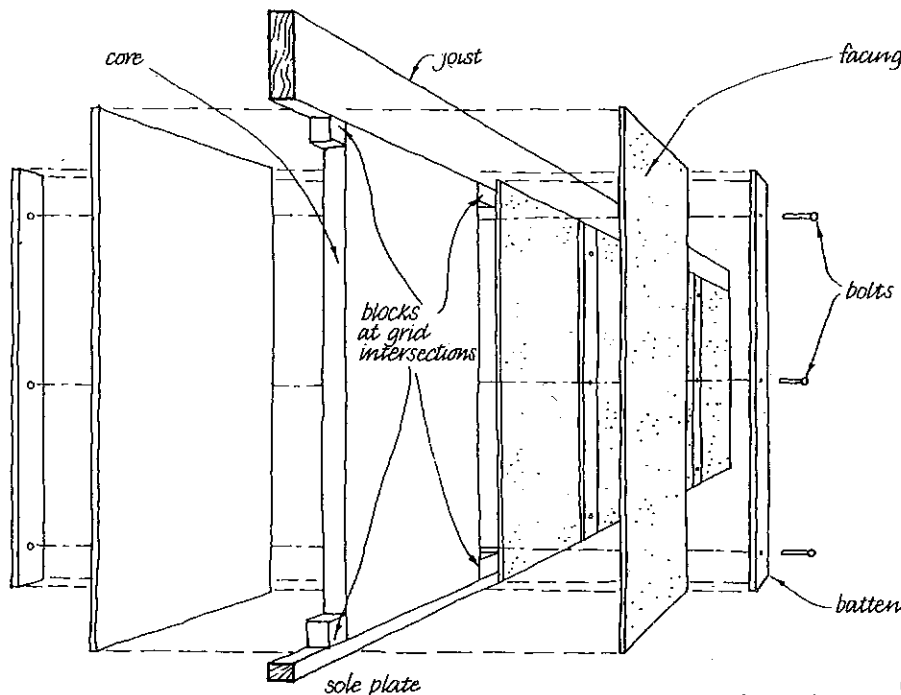

62

Panels are clamped together with timber battens, which are bolted together with three spun galvanised steel bolts. The battens engage on to a sole plate at the bottom and the structural joist at the top, 62. Blocks fixed top and bottom establish the position of the tartan grid, 63. The joint is not sealed, 65. There is a weep hole formed at the bottom of the joint to drain it and to allow ventilation of the wall.

Because the wall is formed of elements simply lapping over one another, conventional tolerances are not relevant. The degree of tolerance provided is much greater, which makes a wall of this kind easy to construct, as the plan view of a junction illustrates, 64.

Components that make up the infill wall, partitions and ceilings are finished as you go along, plasterboards painted and external battens coated with preservative wood stain. Decorating is one of the early operations in the process instead of being one of the last, as is usual.



63

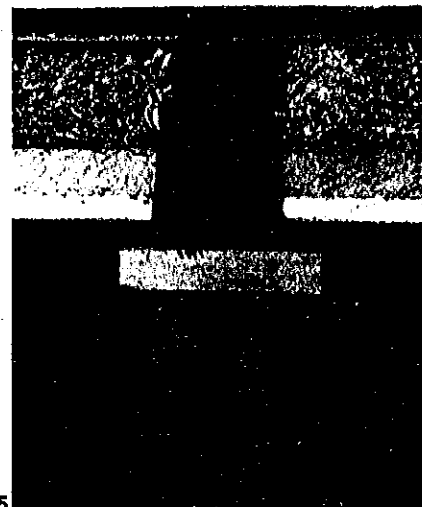

65

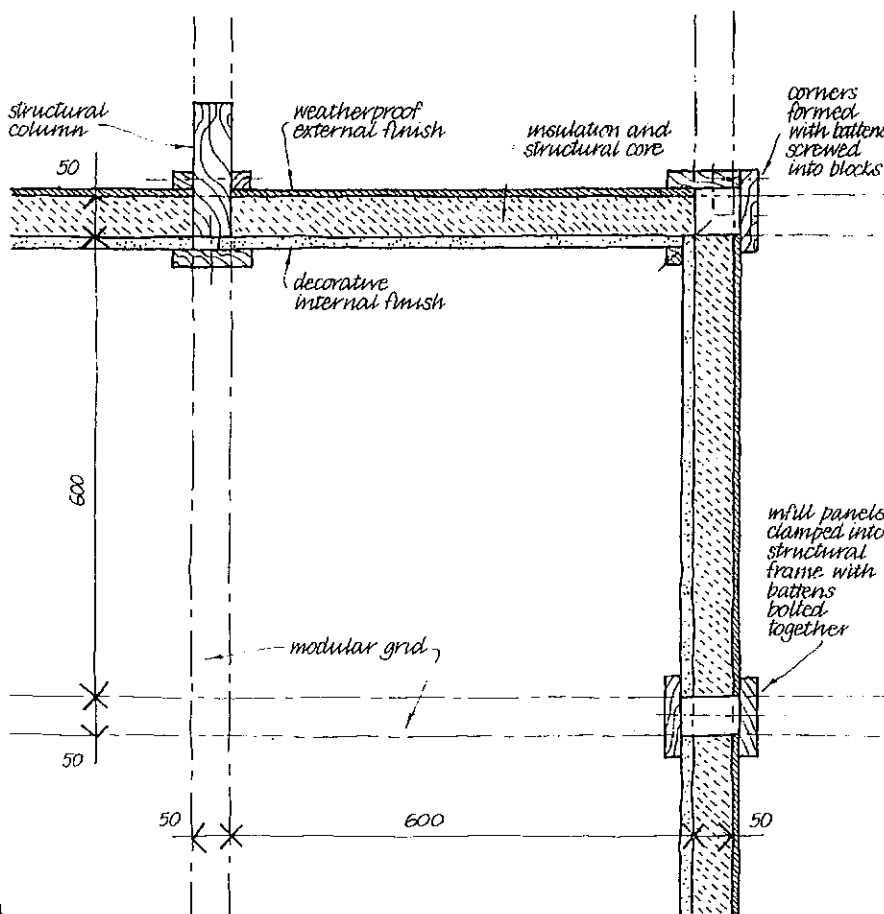

64

15 Windows

Once the external wall panels are in position the building can be made weathertight by fixing the windows, 66. Again, Segal's approach was to assemble easily available materials on site to make a window, rather than incorporate a factory-made component. This avoids the problems of tolerance and modular co-ordination, dependence on a single source of supply and delivery delays. It also reduces costs by eliminating transport and factory overheads.

Windows are in effect sheets of glass with polished edges that slide horizontally in a track made of aluminium angles. These are held in position with timber beads, all within a



66

16 Partitions

Once the building is weathertight the internal subdivisions can be constructed, 71. Partitions are made by clamping panels into the frame with timber battens in a similar way to the external walls. In this case there is a structural core with an internal finish on either side—commonly a 50 mm thick woodwool slab with painted plasterboard on each side. Extra layers can be incorporated as before, for example to provide a pinboard, 72.

Partition panels engage on a sole plate at the bottom and to the structural joist at the top as before, with the blocks fixed top and bottom establishing the tartan grid. Where the partition runs perpendicular to the joists, it is necessary to fix a filler piece at its top.

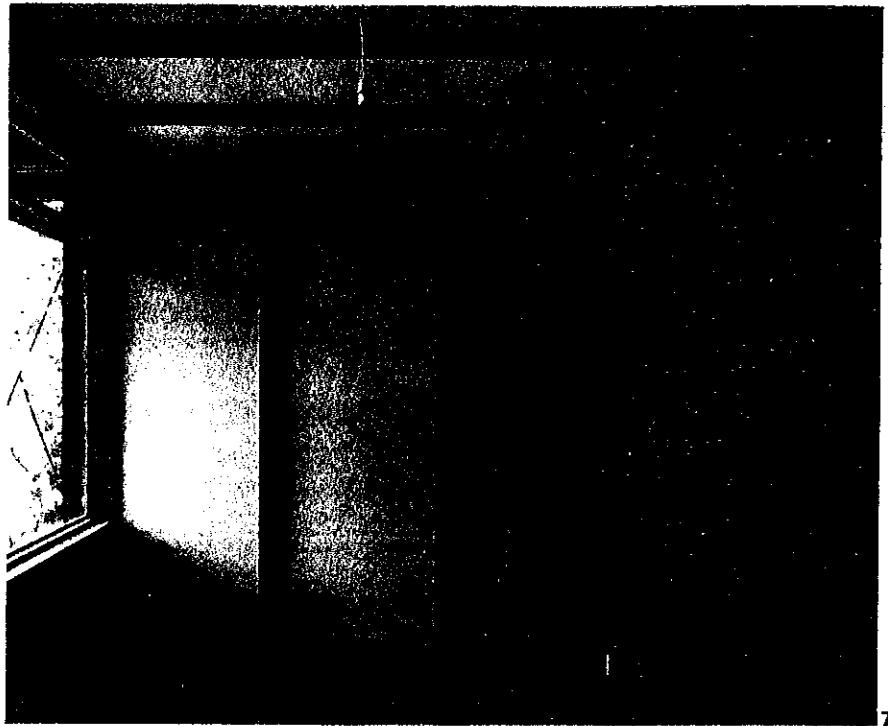

71

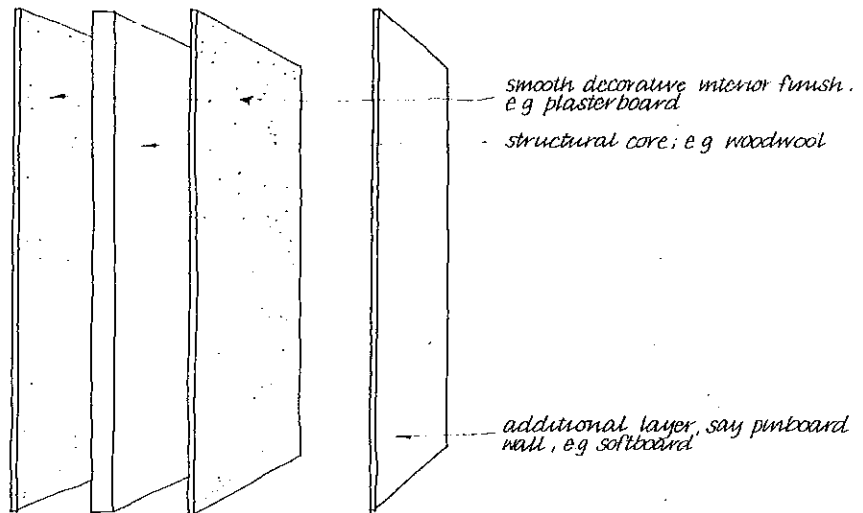

72

Corners and junctions are formed using timber battens as for the external wall. Because the wall is made by overlapping elements clamped together it is possible to offset the boards forming the finish off the modular grid at the corners as necessary to accommodate their thickness, thus avoiding cut panels, 73.

Door linings are made on site and incorporated into the wall. Fixings for shelving and fittings are available at every batten position.

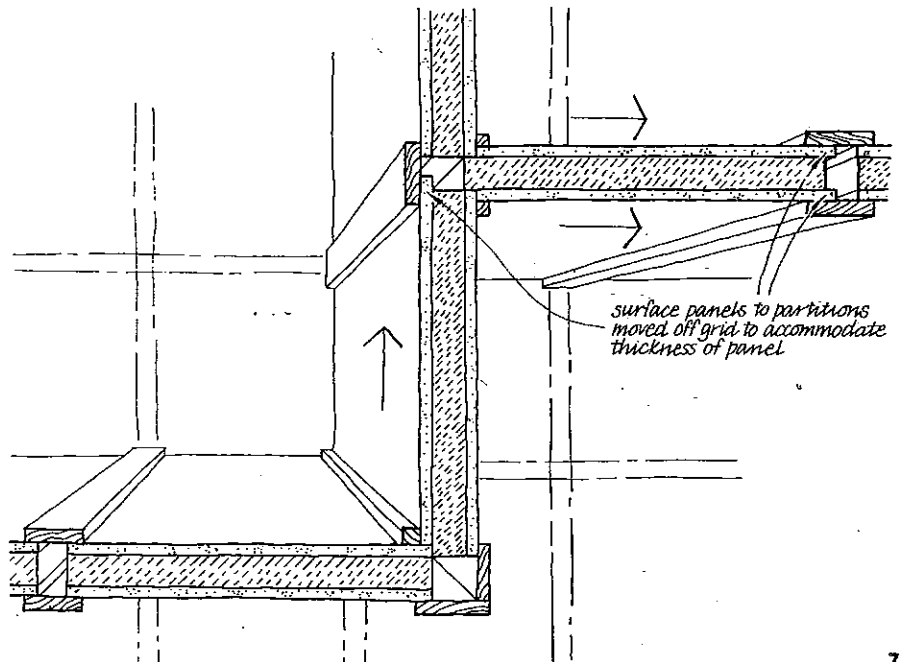

73

THE SEGAL METHOD

window lining. The track is made of two aluminium angles, one of which is fixed through a spacer washer to provide a drainage slot to the track. The angles provide both a sliding surface for the glass and a spacer between the fixed and sliding sheets of glass to give the clearance that is required for the panes to slide past one another, 69. The glass is lubricated by running a wax candle along the edge of the pane before fixing.

Such a window is very adaptable and can be made in a great variety of fixed and opening panes up to about one metre square, to suit the particular building. For example storey height glazing, 67; horizontal strip glazing, 70; varied shapes at the vicarage at Melling by David Lea, 68. Double windows can be formed by constructing a second set inside the first.

The chief disadvantage of a simple window of this kind is that it is not airtight. A clear plastic channel pushed on to the edge of one of the panes closes the 1 mm gap between them and a foam strip seals that part of the drainage slot that is not required below the fixed pane.

Alternatively, the Segal method can incorporate conventional windows of different types.

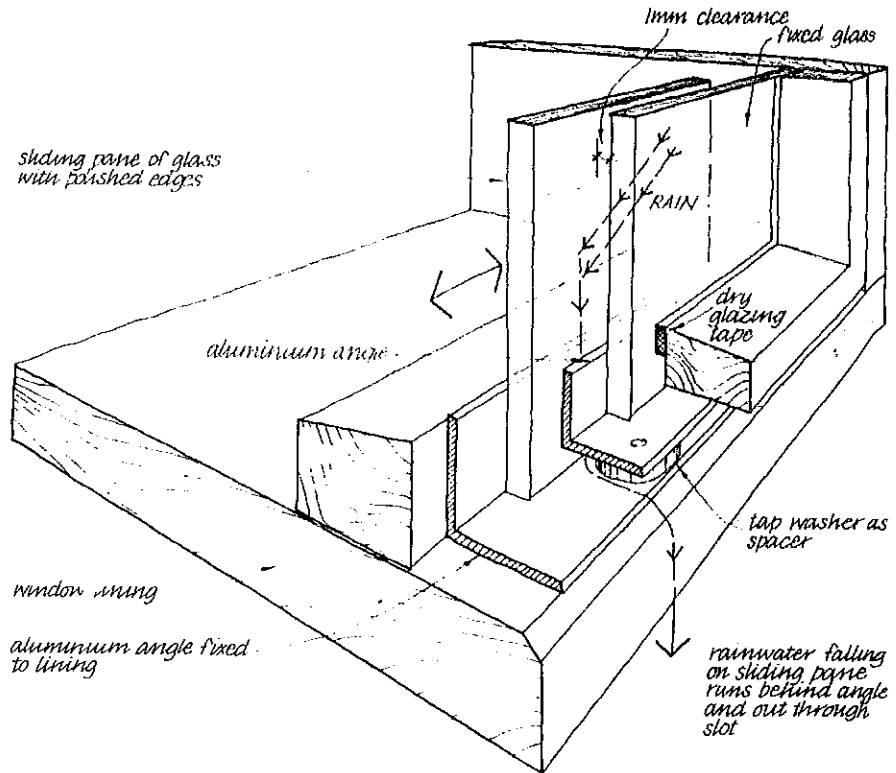

69



67

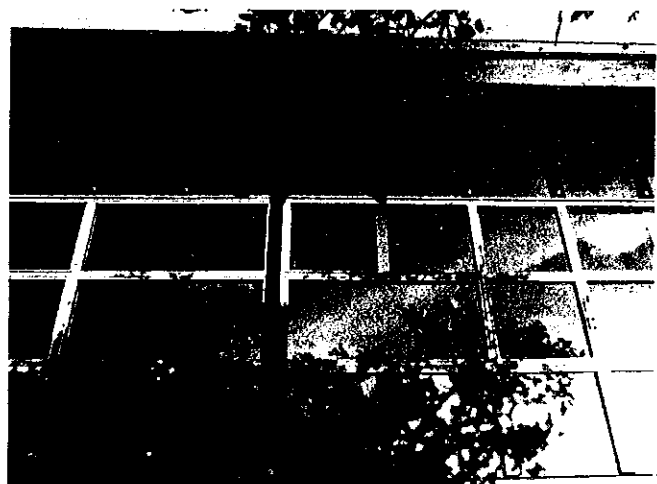

70



17 Ceilings

Once the internal partitions are in place the ceilings can be fixed, 74. They are commonly of painted plasterboard laid between the joists on battens. Generally the boards are 600 mm wide and simply require trimming in length to fit. Some boards only come 1200 mm wide, in which case they have to be cut in half on site. Rooms which are six or more modules wide require two boards end to end with a cover strip to mask the joint.

Other materials and finishes are possible. The ceiling below the roof can include extra insulation. The boards can be lifted out to get access to the services.

The ceiling below a first floor is designed to achieve a modified half hour fire resistance. This is achieved using sacrificial timber linings fixed to the joists. These linings burn in the event of a fire, leaving the structural joists unaffected. This technique, which satisfies the Building Regulations, relies on the fact that timber burns at a predictable rate so that a particular thickness of timber will take a particular length of time to burn through, 75.



74

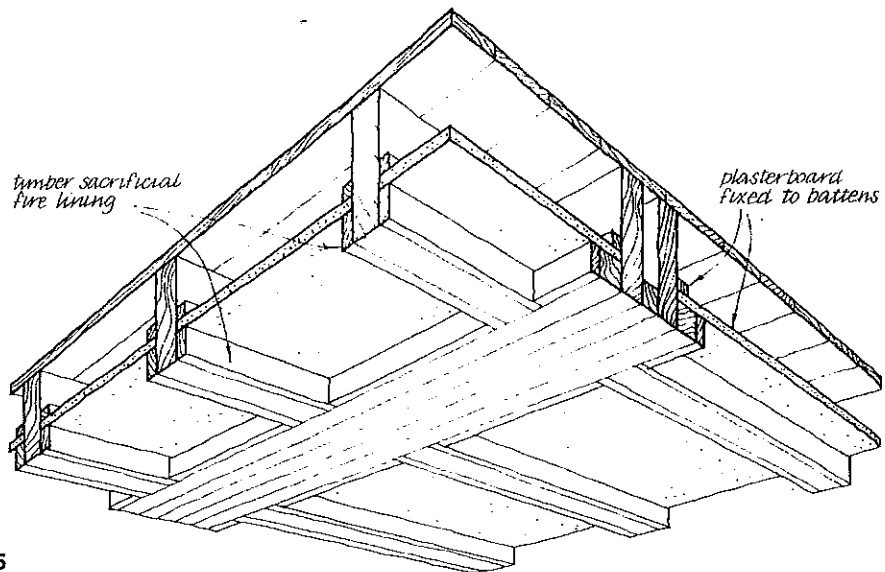

75

18 Stairs and other features

Stairs and steps are designed to avoid complicated setting out, angle cutting and jointing. Treads are supported either on hangars, 76, posts, 77, or cantilever beams, 78. Timber members lap over one another at right angles. Externally, hardwood—generally keruing—is used for treads and walkways, as it is resistant to decay.

The basic structure can be adapted to form any number of different features; pergola, porch, seat, 80, bay window, 79, trellis, veranda, 81, walkway or balustrade. A great degree of variety not only of form but also colour and detail is possible within the discipline of the modular arrangement.



76



77



78



79

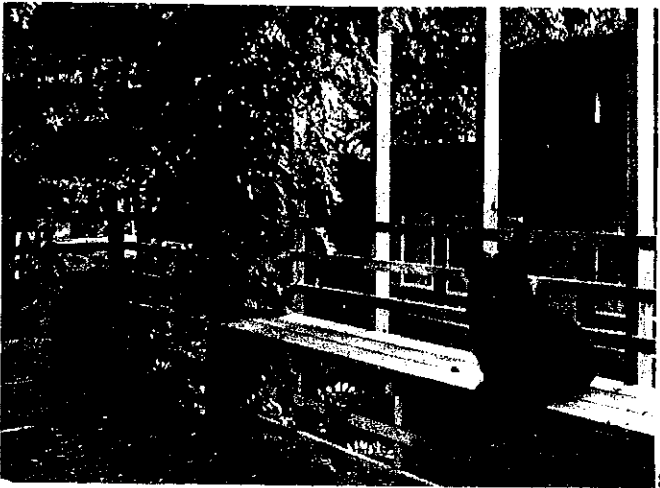

80



81

19 Services

The construction incorporates voids in roofs, floors and walls which accommodate services. These voids are all accessible by unscrewing a batten or lifting out a panel, 83.

Lighting wiring is run in the ceiling void with wiring to light switches dropping down in the spaces between the wall panels at joints. Ring main wiring to power outlets is run in the floor void and rises to socket outlets at batten positions in the wall. Light switches and socket outlets can therefore be positioned on the battens in the wall as convenient by cutting a cabling hole in it, 82.

Pipework for heating, gas and hot and cold water is run in the floor void. Waste pipes from sinks and other fittings can be suspended in the space below the ground floor.

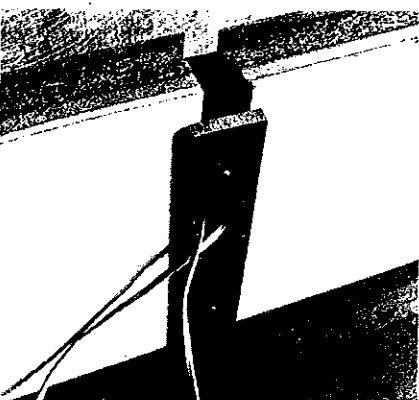
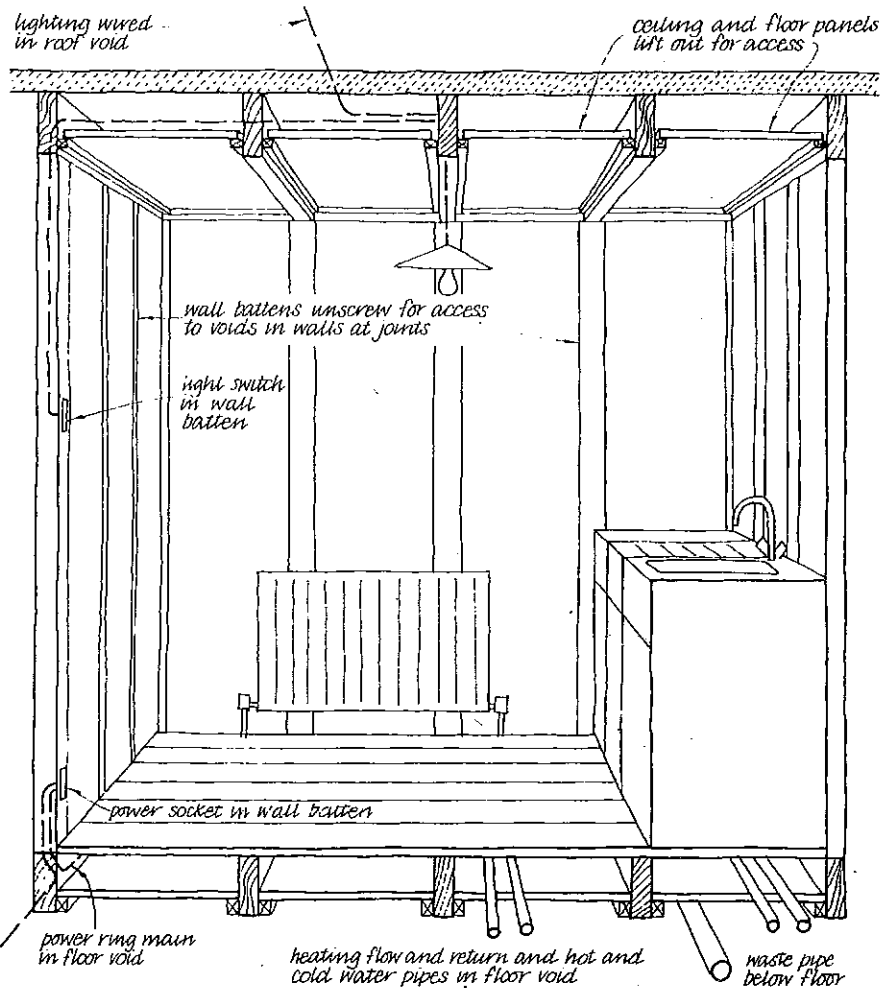

82

83

The future

The Segal method has a number of potentially far reaching implications:

- the role of tradesmen and professionals in the building industry would be altered by this rigorous simplification of the whole building process
- our attitude towards buildings would be changed if they were genuinely adaptable and flexible and no longer fixed edifices designed for a particular purpose, but rather as 'tools' to be put to different uses
- our attitude towards maintenance would alter due to the ease of changing worn out parts
- methods of financing building would change if people were able to build a small, basic initial house capable of easy upgrading and extension
- residents of both public and private developments could enjoy a far greater degree of choice about their accommodation if houses were built using this kit-of-parts approach
- far more people would be able to undertake the construction of their own house using these techniques with the high degree of control, variety and satisfaction that can follow.

While building a house is something that probably only a minority will want or be able to do, it does seem that there is nevertheless a hidden demand which would be satisfied if the opportunities existed and people thought that it was a real possibility. For example, in Sweden, Stockholm City Council has had a departments carrying out self-build developments in and around the city since the 1920s, which presently has a waiting list of 10 000 families.

An important idea is that of choice. The Segal method offers an alternative to subsidised mass housing on the one hand and anonymous mass produced private housing on the other. Making opportunities of this kind available to people who are unemployed would enable them to create something useful for themselves and the community as a whole. They could gain self-confidence which would put them in a much better position to obtain or create useful employment. More generally, one could look forward to land and finance being put into small scale self-regulating communities of self-built houses established on vacant sites in major towns across the country.

Walter Segal became the only living architect as far as I know to get his name into the London A to Z Road Atlas with Segal Close, 84, 85. Walter's Way will be listed next year. Let us hope there will be others.

Jon Broome is a self-builder and was joint architect with Walter Segal for the Lewisham self-build housing schemes.

tographs: Jon Broome, Peter Cook, Nigel
ie, Dougie Firth, Andrew Houston, Phil
r.



84

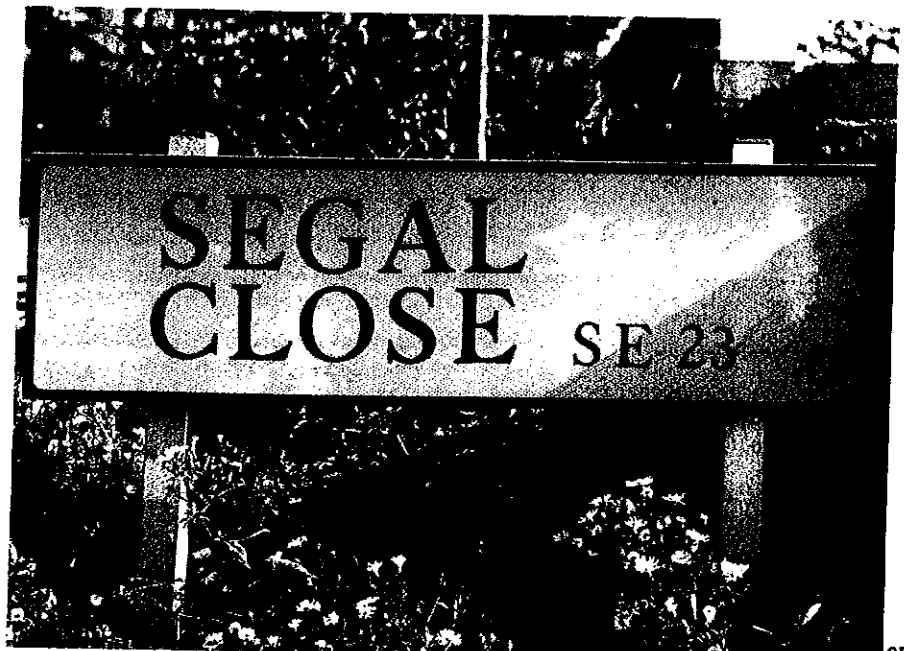

85